

NEC S1300UG Disk Array Unit User Guide

<http://www.manuallib.com/nec/s1300ug-disk-array-unit-user-guide.html>

The information disclosed in this document, including all designs and related materials, is the valuable property of NEC Solutions (America), Inc. and/or its licensors. NEC Solutions (America), Inc. and/or its licensors, as appropriate, reserve all patent, copyright and other proprietary rights to this document, including all design, manufacturing, reproduction, use, and sales rights thereto, except to the extent said rights are expressly granted to others.

ManualLib.com collects and classifies the global product instruction manuals to help users access anytime and anywhere, helping users make better use of products.

<http://www.manuallib.com>

Proprietary Notice and Liability Disclaimer

The information disclosed in this document, including all designs and related materials, is the valuable property of NEC Solutions (America), Inc. and/or its licensors. NEC Solutions (America), Inc. and/or its licensors, as appropriate, reserve all patent, copyright and other proprietary rights to this document, including all design, manufacturing, reproduction, use, and sales rights thereto, except to the extent said rights are expressly granted to others.

The NEC Solutions (America), Inc. product(s) discussed in this document are warranted in accordance with the terms of the Warranty Statement accompanying each product. However, actual performance of each product is dependent upon factors such as system configuration, customer data, and operator control. Since implementation by customers of each product may vary, the suitability of specific product configurations and applications must be determined by the customer and is not warranted by NEC Solutions (America), Inc.

To allow for design and specification improvements, the information in this document is subject to change at any time, without notice. Reproduction of this document or portions thereof without prior written approval of NEC Solutions (America), Inc. is prohibited.

Trademarks

All product, brand, or trade names used in this publication are the trademarks or registered trademarks of their respective trademark owners.

PN: 456-01689-000

July 2003

Copyright 2003
NEC Solutions (America), Inc
10850 Gold Center Drive, Suite 200,
Rancho Cordova, CA 95670
All Rights Reserved

**FEDERAL COMMUNICATIONS COMMISSION
RADIO FREQUENCY INTERFERENCE STATEMENT**

NOTE: This equipment has been tested and found to comply with the limits for a Class A digital device, pursuant to Part 15 of the FCC Rules. These limits are designed to provide reasonable protection against harmful interference when the equipment is operated in a commercial environment. This equipment generates, uses, and can radiate radio frequency energy and, if not installed and used in accordance with the instruction manual, may cause harmful interference to radio communications. Operation of this equipment in a residential area is likely to cause harmful interference in which case the user will be required to correct the interference at his own expense.

Warning

This is a Class A product. In domestic environment this product may cause radio interference in which case the user may be required to take adequate measures.

Contents

Proprietary Notice

Using This Guide

Text Conventions.....	viii
Safety Notices.....	ix
Safety Notices for Users Outside of the U.S.A. and Canada.....	ix
Care and Handling.....	x

1. Overview

Overview.....	1-2
High Capacity Cooling Fans.....	1-4
Power Supplies.....	1-4
Security.....	1-4
DAU Functionality.....	1-5
Hot Spare Feature.....	1-5
Write Cache Feature.....	1-6
Cross Call Feature.....	1-6
Initial Assignment Feature.....	1-7
Auto Assignment Feature.....	1-7
Expand LUN Feature.....	1-8
Auto Repair Mode.....	1-8
Repair Time Feature.....	1-8
1BBU Cache Enable Mode.....	1-9
1CNT (Controller) Cache Enable Mode.....	1-9
Access Control Features.....	1-9
Path Fail-over Feature.....	1-12
Dynamic Capacity Expansion.....	1-12
Management Software.....	1-12
RAID Configurations.....	1-13
Arbitrary Logical Disk Capacity.....	1-14
Maximum Logical Disk Capacity.....	1-14
Features and Indicators.....	1-15
Front Panel.....	1-15
Front Chassis Features and Indicators.....	1-15
Rear Chassis Features.....	1-17
Power Supply.....	1-18
DAU Controller.....	1-19
Battery Backup Unit.....	1-21
SVP Service Processor.....	1-22
Disk Enclosure Controller.....	1-23

2. Setting Up The DAU

Overview.....	2-2
Selecting a Site.....	2-2
Unpacking the DAU and Rack Mounting Hardware.....	2-3
Rack-Mount Subsystem Assembly.....	2-5
Before You Begin.....	2-5

Static Precautions.....	2-5
Installing the Rails	2-6
Installing the DAU into the System Rack.....	2-9
Connecting Disk Array Unit	2-10
Host Connection	2-10
Disk Enclosure Connection.....	2-10
Connecting the Ethernet Cable	2-11
Connection Notes.....	2-12
Setting DAU and Disk Enclosure Switches.....	2-12
Connecting the Power Cords.....	2-13
Connecting the DAU to Uninterruptible Power Supplies	2-15
Cable Dressing.....	2-16
Powering On/Off.....	2-16
Turning On AC Power	2-16
Turning Off AC power	2-17
Scheduled Stop Procedure.....	2-18

3. Adding and Removing Components

General Information.....	3-2
Static Precautions.....	3-2
Preparing Your DAU for Upgrade.....	3-3
Accessing the DAU.....	3-3
Hard Disk Drives	3-4
Installing or Swapping a Hard Disk Drive Modules in a Hot-swap Bay	3-4
Installing or Swapping a Hard Disk Drive.....	3-5
Replacing a Controller Module.....	3-7
Replacement Procedure	3-7
Replacing a SVP Service Processor.....	3-11
Replacement Procedure	3-11
Replacing the Power Supply	3-14
Replacement Procedure	3-14
Replacing the Battery Backup Unit.....	3-20
Replacement Procedure	3-20

4. Maintenance and Troubleshooting

Introduction.....	4-2
Static Precautions.....	4-2
Routine Maintenance	4-2
Cleaning	4-2
Initial DAU Startup Problems.....	4-3
Troubleshooting	4-4
LED Indicators.....	4-5
SERVICE LED: On / FLT LED: Off.....	4-5
Troubleshooting Flowcharts	4-6
Media Errors on a Rebuilt Disk	4-8
Temporary Degrade and Rebuild (Phoenix Feature)	4-8

A. Controller DIP Switch Settings

Controller DIP Switch Settings.....	A-2
-------------------------------------	-----

B. Specifications

Disk Array Unit Basic Specifications	B-2
Environmental Specifications	B-2
Power Specifications	B-2
Size and Weight Specifications	B-3
Component Life Expectancies	B-3

Equipment Log

Glossary

Index

Using This Guide

This User's Guide provides a quick reference to information about your S1300 Disk Array Unit (DAU). Its goal is to familiarize you with your DAU and the tasks necessary for setting up your DAU, using the DAU, and configuring and upgrading the DAU. This guide assumes that the reader is already familiar with the host system, Fibre Channel technology, and operating system environments in which the DAU will be installed.

This guide contains the following information:

- Chapter 1, "DAU Overview" provides an overview of your DAU and describes its major system components. See this chapter to familiarize yourself with your DAU.
- Chapter 2, "Setting Up Your DAU" tells you how to select a site, unpack the DAU and provides you with assembly information for preparing and mounting the DAU into a system rack. Also described are DAU to host cabling configurations, connecting the power cord(s), powering On/Off the DAU, and configuring the Fibre Channel address switches.
- Chapter 3, "Adding and Removing Components" provides you with information for upgrading your DAU with additional disk drives. Information on a power supply, battery backup unit, controller module and the SVP processor module are also included.
- Chapter 4, "Maintenance and Troubleshooting" contains helpful information for maintaining your DAU and for solving problems that might occur with your DAU.
- Appendix A, "Controller DIP Switch Settings" contains information on setting DIP switches located in the controller modules.
- Appendix B, "Specifications" includes physical, power, and environmental information about your system.
- "Glossary" defines the standard acronyms and technical terms associated with the DAU.

Text Conventions

This guide uses the following text conventions.

Warnings, cautions, and notes have the following meanings:

WARNING

Warnings alert you to situations that could result in serious personal injury or loss of life.

CAUTION

Cautions indicate situations that can damage the system hardware or software.

 **Note:** Notes give important information about the material being described.

- Names of keyboard keys are printed as they appear on the keyboard. For example, **Ctrl**, **Alt**, or **Enter**.
- Text or keystrokes that you enter appear as boldface type. For example, type **abc123** and press **ENTER**.
- File names are printed in uppercase letters. For example, **AUTOEXEC.BAT**.

Safety Notices



- **Caution:** To reduce the risk of electric shock which could cause personal injury, follow all safety notices. The symbols shown are used in your documentation and on your equipment to indicate safety hazards.
- **Warning:** The detachable power supply cords are intended to serve as the disconnect devices.
- **Warning:** This equipment has a 3-wire, grounded power cords. To prevent electrical hazards, do not remove or defeat the ground prong on the power cords. Replace a power cord if it gets damaged. Contact your dealer for an exact replacement.

In the U.S.A. and Canada, the power cord must be a UL-listed detachable power cord (in Canada, CSA-certified), type ST or SJT, 16 AWG, 3-conductor, provided with a molded-on NEMA type 5-15 P plug cap at one end and a molded-on cord connector body at the other end. The cord length must not exceed 9 feet (2.7 meters).

Outside the U.S.A. and Canada, the plug must be rated for 250 VAC, 10 amp minimum, and must display an international agency approval marking. The cord must be suitable for use in the end-user country. Consult your dealer or the local electrical authorities if you are unsure of the type of power cord to use in your country. The voltage change occurs via a switch in the power supply.

- **Warning:** Under no circumstances should the user attempt to disassemble the power supply. The power supply has no user-replaceable parts. Inside the power supply are hazardous voltages that can cause serious personal injury. A defective power supply must be returned to your dealer.

Safety Notices for Users Outside of the U.S.A. and Canada

- **PELV (Protected Extra-Low Voltage) Integrity:** To ensure the extra-low voltage integrity of the equipment, connect only equipment with mains-protected electrically-compatible circuits to the external ports.
- **Remote Earths:** To prevent electrical shock, connect all local (individual office) computers and computer support equipment to the same electrical circuit of the building wiring. If you are unsure, check the building wiring to avoid remote earth conditions.
- **Earth Bonding:** For safe operation, only connect the equipment to a building supply that is in accordance with current wiring regulations in your country. In the U.K., those regulations are the IEE.

Care and Handling

Use the following guidelines to properly handle and care for your system.



Protect the system from extremely low or high temperatures. Let the system warm (or cool) to room temperature before using it.



Keep the system away from magnetic forces.



Keep the system dry. Do not wash the system with a wet cloth or pour fluid into it.

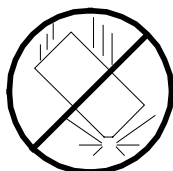

Protect the system from being bumped or dropped.



Check the system for condensation. If condensation exists, allow it to evaporate before powering on the system.



Keep the system away from dust, sand, and dirt.

1

Overview

- Overview
- High Capacity Cooling Fans
- Power Supplies
- Security
- DAU Functionality
- Features and Indicators

Overview

The NEC S1300 Disk Array Unit (DAU) provides highly available, fault-tolerant storage in a rack-mount subsystem. The DAU uses high-speed Fibre Channel technology. See Figure 1-1.

The Fibre Channel is a scalable, high-performance interconnect standard that enables fast transfer of data between workstations, shared storage, peripherals and host systems. At up to speeds of 2 Gigabits per second this data transfer technology combines the attributes of a data channel with the attributes of a network. Fibre Channel is capable of supporting multiple protocols and a variety of topologies, making it the most versatile data transfer technology available.

The DAU supports RAID levels 0, 1, 5, and 10. Even if one disk module fails, the disk array unit continues to function normally without interruption (Except for RAID level 0).

A faulty disk module can be replaced without system shutdown. The DAU includes an automatic rebuild feature by which data is automatically restored when a faulty disk module is replaced. When one disk module is defined as a spare drive, the data in the faulty disk module is immediately restored to the spare drive (hot spare feature). Using the auto recovery and hot spare feature increases overall system availability and reliability.

The DAU also includes a battery-backed cache memory data storage feature to increase reliability and high-speed data processing. In addition to the disk modules, the cooling fan system, the power supply system, and dual array controllers all have system redundancy capabilities. Therefore, even if one of the redundant system components fails, the disk array unit continues normal operation.

The DAU cabinet holds up to a maximum of fifteen hard disk drives. A disk enclosure unit (option) is available to enable expansion of the storage capacity of the DAU by adding up to fifteen additional hard disk drives.

The DAU has a relatively small form factor of 3U and is available as a rack-mount system that fits into a standard EIA 19-inch rack assembly.

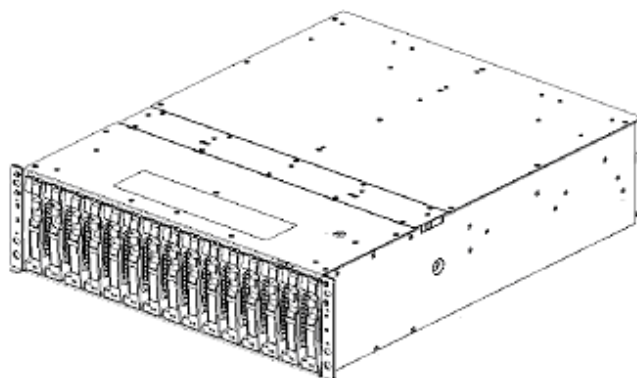

Figure 1-1. Rack-Mount DAU Front View (Front Bezel not Shown)

The DAU includes the following major features:

- 2.0 Gigabit per second data transfer rate .
- High bandwidth for demanding applications.
- The ability to share storage assets among many workstations.
- Easy cabling to host bus adapters.
- Hot-swap hard disk drive bays accessible from the front of the chassis. The drives can be swapped in or out of the DAU without powering it down. The bays support up to fifteen hard disk drives. Disk drives are high performance 10,000RPM and 15,000RPM hard disk drives connected to a high speed Fibre Channel-Arbitrated Loop (FC-AL) disk drive interface. Drive capacities are 36GB, 73GB or 146GB.
- Hardware monitors (temperature, fans, and voltage) and software monitors to indicate failures.
- LEDs to provide failure notifications.
- Support of RAID levels 0, 1, 5, and 10. If a fault occurs in a single disk module, the DAU can continue the operation without loss of data (except RAID level 0).
- Battery-backed cache memory to ensure high-speed data processing.

The DAU system is designed for minimum downtime. Thus, the DAU contains the following:

- A more reliable and flexible storage architecture that helps ensure continuous data availability.
- Two power supplies for power system redundancy. With two power supplies, the DAU will continue to operate with a single power supply failure. The self-contained power supply units can be easily and safely hot-swapped from the rear of the chassis without shutting down the DAU.
- Dual controllers, each containing cache memory. Cache memory data is protected by battery backup units, to retain write data in the event of a system shutdown or power failure.
- Fibre Channel disk drive bays accessible from the front of the chassis.
- Hot-swap Fibre Channel disk drive backplane, supporting fifteen drives. A failed drive can be removed and a new drive installed without turning off system power.

■ Disk Drive Bays

The DAU supports 36GB, 72GB and 146GB hard disk drives. The chassis includes fifteen Fibre Channel hot-swappable hard disk drive bays for mounting up to fifteen hard disk drives in easily removable drive carriers. Each bay accommodates 1-inch hard disk drives.

 **Note:** The DAU contains a hot-swap backplane that requires a 40-pin single connector attachment connector on the drives that you install.

The design of the drive mounting uses a carrier rail system making it possible to "hot swap" a drive without shutting down the DAU.

High Capacity Cooling Fans

The DAU contains two power supplies, each of which contains two high capacity cooling fans. The DAU will be adequately cooled even if one of the fans fails. Also, should any of the fans fail, they may be replaced without powering down the DAU. The fans draw air across the hard disk drives and electronics of the system and exhaust out through the rear panel.

Power Supplies

The DAU contains two auto-sensing 480-watt power supplies at an operating frequency of 50/60 Hz. With two power supplies installed, in the event of a power supply failure, the load is transferred to the remaining power supply without interruption to normal operation.

 **Note:** The power supplies are not hot swappable unless there are two supplies installed.

The power supplies are designed to comply with existing emission standards and provide sufficient power for a fully loaded system configuration.

Security

A security lock on the front bezel of the DAU prevents unauthorized entry to the storage drives. Rack-mounted DAUs are also secured in the system cabinet by locking mechanisms installed on the system rack front and rear doors.

DAU Functionality

Hot Spare Feature

Spare disks can be installed in a disk array configuration that includes several disks. If a disk fails in a configuration that includes the spare disk, the data located in the defective disk is recovered to the spare disk. After the data recovery, the disk array configuration operates normally. The defective disk module can be replaced without turning off the power of the disk array unit, provided the disk array unit is configured as RAID level 1, 5, or 10.

To use the hot-spare feature, an optional spare disk must be installed.

An example of the hot spare feature is shown in Table 1-1. In this example, hard disk drives DRV0, 1, 2, 3, 4, and 14 are configured as a disk array. DRV14 is designated as the spare disk. Disk DRV1 fails and its data is recovered in spare disk DRV14. When recovery is complete, disk DRV1 is replaced without powering down the unit. Once disk DRV1 is replaced, data is restored from spare disk DRV14 to the new disk DRV1.

Table 1-1. Hot Spare Feature Example

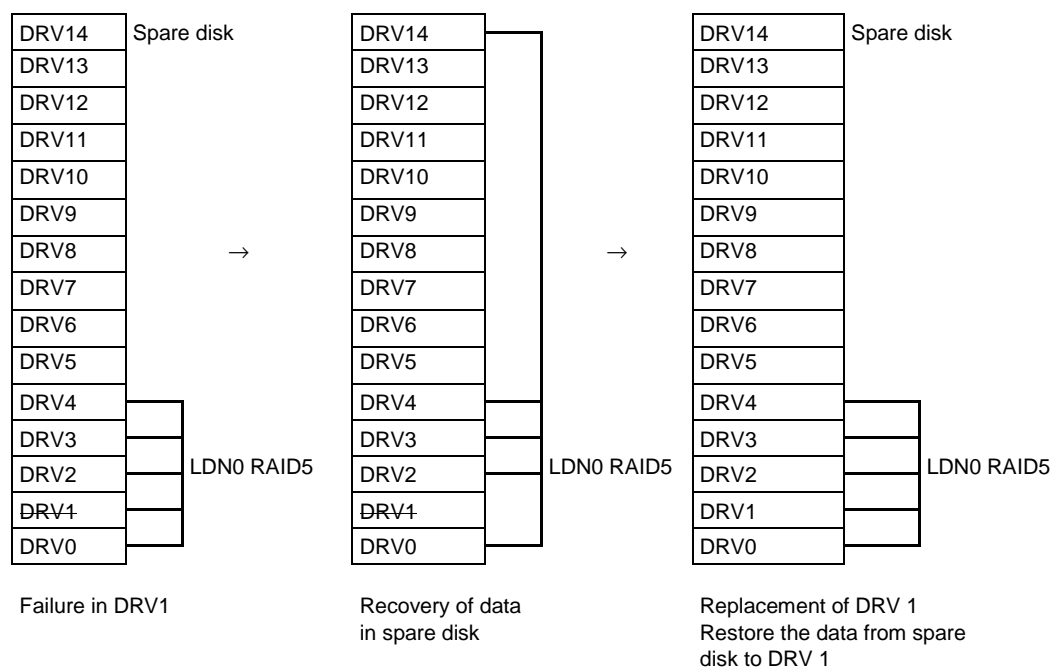

* *DRV: Disk module*
LDN: Logical Disk Number

Notes: The hot spare feature cannot be used with RAID level 0. Use the hot spare feature with RAID levels 1, 5, or 10.

Do not move any factory-installed disk modules into another slot.

The hot spare feature works only when a spare disk has the same capacity and speed as the defective disk.

Write Cache Feature

With RAID level 5, the performance of the DAU may be decreased somewhat when writing small amounts of data to a disk. To increase performance, the DAU is equipped with cache memory. When write data is stored in cache memory, the DAU may terminate command processing and then write data to disks for improved performance.

However, if the power is disrupted before the data in cache memory is written to disk, the data in the cache memory could be lost. To prevent this, the DAU power supplies each include a battery backup unit to supply power to the cache memory, thereby retaining data in the cache memory should the power fail. The battery backup unit is fully charged after eight hours of operation.

Cross Call Feature

By using the cross call feature, logical disk drives can be accessed from alternative paths within the DAU, even if a controller fails. The cross call feature minimizes server downtime thereby enhancing system performance. The cross call feature of the DAU can be set with management software. The cross call feature has two states:

- **Off state** In this state, the DAU is accessible only from the host adapter (HBA) of the bound host.
- **On state (shipping default)** In this state, all logical drive numbers (LDNs) in the DAU are accessible from both controllers or one controller should one of the controllers fail.

 **Note:** Since one LDN is recognized from each controller, this cross call must be used on the system where the logical disks can be controlled exclusively. When you want to use the alternative path switching feature of the host, the cross call feature must be turned on.

Figure 1-2 illustrates a system connected to the DAU with the cross call feature turned on and a failure with DAU controller HD#1.

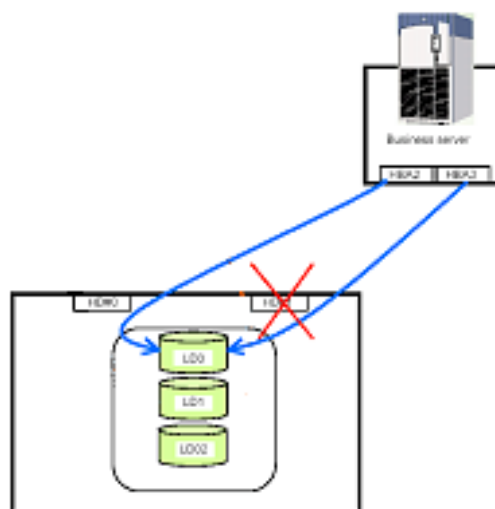



Figure 1-2. Cross Call Feature Connections

 **Notes:** A controller is called as HD (Host Director) in the management software.

A logical disk configuring the RAID is called as LD (Logical Disk), and the internal number of LD is called LDN (Logical Disk Number) in the management software.

Initial Assignment Feature

You can assign a logical disk to the controller on the path to which you bound the logical disk (built the RAID).

When an attempt is made to access the logical disk from the unassigned controller, the error "illegal request - not assigned" is returned. When an attempt is made to unbind this logical disk from the unassigned controller, the same error is returned. However, if the ownership has been changed, the initial assignment feature is transferred to the unassigned controller.

Auto Assignment Feature

The auto assignment feature allows you to access any logical disk in the subsystem from the unassigned controller if the assigned controller is down. This feature is active while the cross call is disabled.

When an I/O request to a logical disk not assigned to a DAU controller is received, the system examines whether the adjacent controller is down. If the adjacent controller is down, the system cancels assigning the logical disk to that controller and reestablishes the assignment to the controller receiving the request. This reassignment is maintained until the downed controller is operable, or a status change is received from management software.

Even when the system is not equipped with the alternative auto assignment feature, making the system recognize the logical disk again permits the access, allowing to minimize the influence to the system operation. Figure 1-3 illustrates the Auto assignment feature.

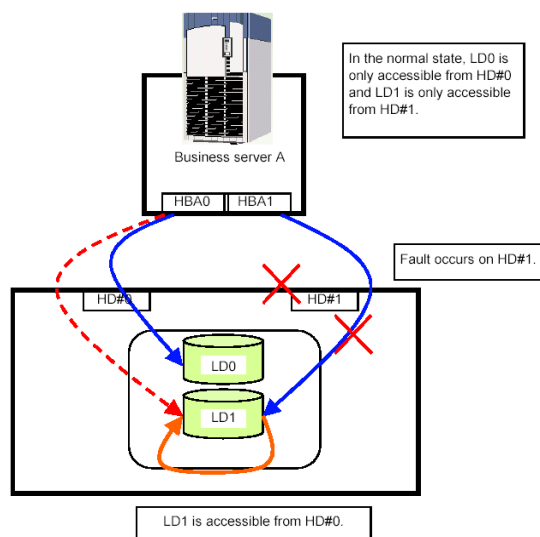



Figure 1-3. Auto Assignment Feature

Expand LUN Feature

The Expand LUN feature increases the number of logical disks available from the host.

When running Windows NT or Windows 2000, the expand LUN feature is disabled (shipping default). This setting can be changed with the NEC Storage Manager (management software).

 **Note:** When the DAU is connected to a host server that does not support the Expand LUN feature, and this feature is turned on, the host server may not recognize the DAU. If this occurs, the default setting (Expand LUN feature off) may not be restored with the NEC Storage Manager management software, resulting in system fault.

Auto Repair Mode

When the disk array includes an unused spare disk, you can select whether the repair operation is started automatically or manually by using the NEC Storage Manager management software. Auto repair mode is set to enable (shipping default).

 **Notes:** If auto repair mode is disabled during a repair, the current repair continues and is not terminated. The new setting will take affect for the next repair.

When auto repair mode is enabled in the standby state, the repair is not immediately initiated. The new setting will take affect for the next repair.

When auto-repair mode is turned on and the physical disk status is examined from the management software, "rebuilding" status is displayed indicating the repair is in process. When auto-repair is turned off and a disk fails, the status "reduce" is displayed until the rebuild process is started manually.

Repair Time Feature

The default repair time is 10 hours. This time can be set from 0 (fastest) to 24 hours. However, the repair might not be completed within the predetermined time depending on the required repair. If a repair time is not specified, the fastest possible repair is automatically executed.

With the repair time set to the shortest value (0), the RAID redundancy is rebuilt as fast as possible to minimize exposure to a second failure. Setting the repair time to 24 hours minimizes loss of performance during the repair.

1BBU Cache Enable Mode

Normally your DAU includes two battery backup units to retain write data in the cache memory of each controller in the event of a system shutdown or power failure. When only one battery backup unit is in service, the DAU is not redundant and data loss may occur if this battery unit fails. For this reason, it is recommended that 1BBU cache enable mode be turned off when only one battery backup unit is in use.

OFF state: The write cache is disabled in the single-BBU condition.

ON state: The write cache is enabled even in the single-BBU condition. (Shipping default)

1CNT (Controller) Cache Enable Mode

Normally your DAU includes two controllers, each containing cache memory to retain write data in the event of a system shutdown or power failure. When only one controller is in service, the DAU is not redundant and lost data may occur if the cache in this controller is enabled and this controller fails. For this reason, it is recommended that 1CNT cache enable mode be turned off when only one controller is in use.

OFF state: The write cache is disabled in the single-controller condition. (Shipping default)

ON state: The write cache is enabled even in the single-controller condition.

Access Control Features

Objective of Access Control

Access control allows logical disks in a DAU the ability to establish port and host access permissions. Access control also provides a logical disk masking feature on a port-by-port or host-by-host basis to protect the data and ensure the security.

About Access Control

To achieve the above objectives, the access control determines those logical disks accessible from the controller or host and masks these disks. When you want to use the access control, the cross call feature must be turned on.

Modes Supported by Access Control

The access control feature supports the following two modes.

- Port mode
- WWN mode

Port Mode

Port Mode establishes and maintains the logical disks accessible from each port (controller) in the DAU. Table 1-2 shows logical disks assigned to each port in a DAU. Figure 1-4 shows two business servers and the logical disks (LDs) assigned to each using port mode. Business server A can access logical disks LD0, LD01, LD04, and LD06 while business server B can access logical disks LD02, LD03, LD05, and LD07. LD08 and LD09 are inaccessible from either business server.

Table 1-2. Setup of HD and LD Numbers

Hard Disk (HD) Port Number	Logical Disk Number (LD)									
	00	01	02	03	04	05	06	07	08	09
0	√	√	-	-	√	-	√	-	-	-
1	-	-	√	√	-	√	-	√	-	-

Legends

- √: Registers the HD number in the access limitation list as accessible number.
- : Registers the HD number in the access limitation list as inaccessible number.

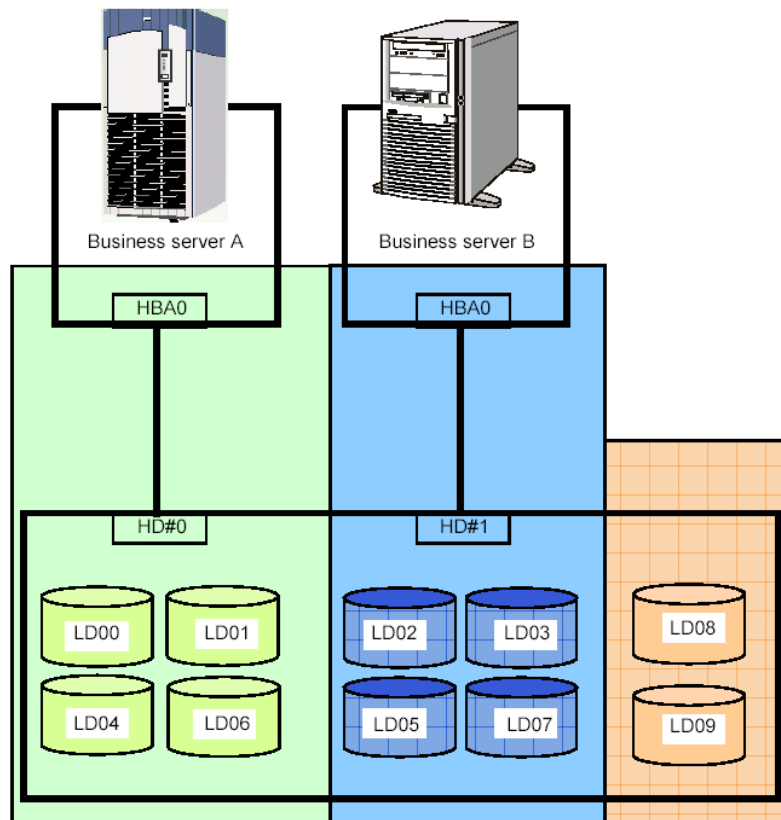

Figure 1-4. Port Mode Logical Drives Assignments to Business Servers

WWN (World Wide Node) Mode

WWN mode establishes and maintains the logical disks accessible from each WWN of the host HBA in the DAU to control the access to the logical disks on a host-by-host basis. Table 1-3 shows logical disks assigned to each HBA. Figure 1-5 shows two business servers and the logical disks (LDs) assigned to each using WWN mode. Business server A can access logical disks LD00, LD01, LD04, and LD06 while business server B can access logical disks LD02, LD03, LD05, and LD07. LD08 and LD09 are inaccessible from either business server. If business server A supports the path switching feature, the logical disks of HD#0 are accessible through switch 1 even when switch 0 is unavailable and access is rejected.

Table 1-3. Setup of WWN and LD Numbers

Host Bus Adapter (HBA) Number	Logical Disk Number (LD)									
	00	01	02	03	04	05	06	07	08	09
0	√	√	-	-	√	-	√	-	-	-
1	Δ	Δ	-	-	Δ	-	Δ	-	-	-
2	-	-	√	√	-	√	-	√	-	-

Legends

- √: Registers the HBA WWN and HD number in the access limitation list as accessible items.
- : Registers the HBA WWN and HD number in the access limitation list as inaccessible items.
- Δ: Registers the WWN of HBA0/HBA1 and the HD number in the access limitation list as accessible items. If the business server A supports the path switching feature, the logical disks are accessible through switch 1 even in case that switch 0 is faulty and the access is rejected.

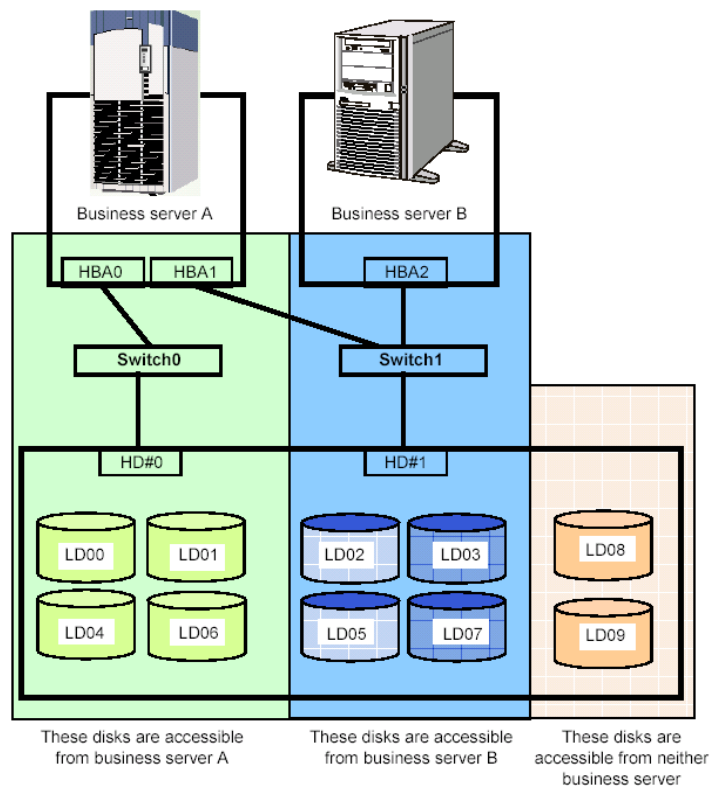

Figure 1-5. WWN Mode Logical Drives Assignments to Business Servers

Path Fail-over Feature

The DAU is equipped with two disk array controllers to enable dynamic cross call control. The two disk array controllers can access to all logical disks. If either of the disk array controllers fails, the DAU can continue the operation by using the remaining disk array controller. In order to use this function, optional software may be required, as well as the operating system.

Dynamic Capacity Expansion

The Dynamic Capacity Expansion feature can be used to add capacity to the RAID 5. RAID 5 configurations of 3 to 14 drives can be expanded. Physical disks may be added one at a time, and the expansion can be started only after the previous expansion has completed. NEC Storage Management or MSMGR are used to initiate the expansion.

Management Software

NEC Storage Management software provided with your DAU, allows you to perform the following functions from the host computer:

- Setting and resetting RAID configurations (RAID0, 1, 5, 10, and hot spare disk)
- Setting of various features
- Downloading firmware updates
- Collecting error logs.

RAID Configurations

Available DAU RAID configurations are shown in Table 1-4.

Table 1-4. RAID Configurations

RAID Level		RAID0	RAID1	RAID5	RAID10
Number of physical drives in configuration		1, 3, 5, 10, 15	1+1	2+1 to 14+1	2+2 to 7+7
Number of logical drives per subsystem		1,024 max.			
Storage capacity per logical drive	With 36-GB disks	35.7 to 536.1GB	35.7GB	71.4 to 500.3GB	71.4 to 250.1GB
	With 73-GB disks	71.6 to 1074GB	71.6GB	143.2 to 1002GB	143.2 to 501.2GB
	With 146 GB disks	142.9 to 2144GB	142.9GB	285.8 to 2001GB	285.8 to 1000GB

* A combination of disk modules of the same capacity and same rotational speed are required for configuring logical drives.

Characteristics of the RAID levels are shown in Table 1-5.

Table 1-5. RAID Level Characteristics

Level	Function	Advantage	Disadvantage
RAID0	Striping	Highest data read/write rate Maximum storage capacity	Data recovery disabled (Fault in a single disk module causes data to be lost.)
RAID1	Mirroring All data is written to two disk modules.	Data recovery enabled Minimum data recovery time	Low-speed data writing The required disk capacity is twice the used storage capacity.
RAID5	Striping of data and redundant data	Data recovery enabled Larger capacity is available for users because the capacity of redundant data is smaller than that of RAID1. High-speed data write	Three or more disk modules are required. The required storage capacity is one extra physical disk per rank.
RAID10	Use of both mirroring and striping	Data recovery enabled High-speed data read/write	Four or more disk modules are required. The required storage capacity of disk module is twice the used storage capacity.

Arbitrary Logical Disk Capacity

An arbitrary logical disk capacity can be bound by using the management software. To bind logical disks, enter the capacity in MBs ($M=1024^2$).

For management software, the logical disk capacity can be specified with an integer multiple of the basic capacity, or the least common multiple of (stripe size) \times (number of data disks) and 1024 (400h).

Ex: Capacity secured in RAID-5 (6+P)

Stripe size (100h) \times number of data disks (6h) = 600h (768 KB)

The basic capacity is the least common multiple of 400h and 600h.

The capacity must be an integer multiple of C00h (1536 KB).

Maximum Logical Disk Capacity

The maximum capacity per logical disk is shown in the table below (including the system capacity of 2 MB).

Enter the value resulting from subtracting the system capacity (2 MB) from the capacity in Table 1-6 as the LD capacity.

Table 1-6. Maximum Logical Disk Capacity (MB) $M=1024^2$

RAID Type	Number of PDs	36GB	73GB	1476GB
Single unit		34087	68284	136325
RAID0 (1)	1	34087	68284	136325
RAID0 (3)	3	102261	204852	408975
RAID0 (5)	5	170435	341420	681625
RAID0 (10)	10	340870	682840	1363251
RAID0 (15)	15	511305	1024260	2044876
RAID1 (1+1)	2	34087	68284	136325
RAID5 (2+P)	3	68174	136568	272650
RAID5 (3+P)	4	102261	204852	408975
RAID5 (4+P)	5	136348	273137	545300
RAID5 (5+P)	6	170435	341420	681625
RAID5 (6+P)	7	204522	409704	817950
RAID5 (7+P)	8	238609	477988	954275
RAID5 (8+P)	9	272697	546274	1090600
RAID5 (9+P)	10	306783	614556	1226926
RAID5 (10+P)	11	340870	682840	1363251
RAID5 (11+P)	12	374957	751124	1499576
RAID5 (12+P)	13	409044	819411	1635901
RAID5 (13+P)	14	443131	887692	1772226
RAID5 (14+P)	15	477218	955976	1908551
RAID10 (2+2)	4	68174	136568	272650
RAID10 (3+3)	6	102261	204852	408975
RAID10 (4+4)	8	136348	273137	545300
RAID10 (5+5)	10	170435	341420	681625
RAID10 (6+6)	12	204522	409704	817950
RAID10 (7+7)	14	238609	477988	954275

*Note:*The capacities in the table above include the system capacity (in T&D area) of 2 MB.

Features and Indicators

The DAU contains several features and indicators located on the front and rear of its chassis. The LED indicators assist in determining the current state of the DAU subsystem. The following subsections describe the front and rear chassis features and indicators of the DAU.

Front Panel

Figure 1-6 shows the front bezel and the indicators visible when the front bezel is installed. The front bezel can be removed by releasing the lock with the accessory key. Grasp the sides of the bezel and pull the bezel toward you. The power and service LEDs are described in Figure 1-7.

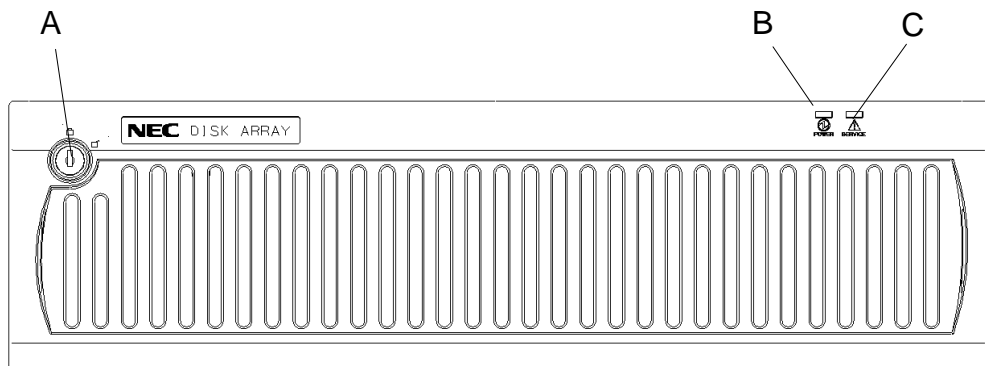

- A Security Lock
- B Power LED (green)
- C Service LED (Orange)

Figure 1-6. Front Chassis Features and Indicators (Bezel Installed)

Front Chassis Features and Indicators

Figure 1-7 shows the features and indicators located on the front of the DAU with the front bezel removed. Disk modules are labeled 00 – 14 and are installed left to right.

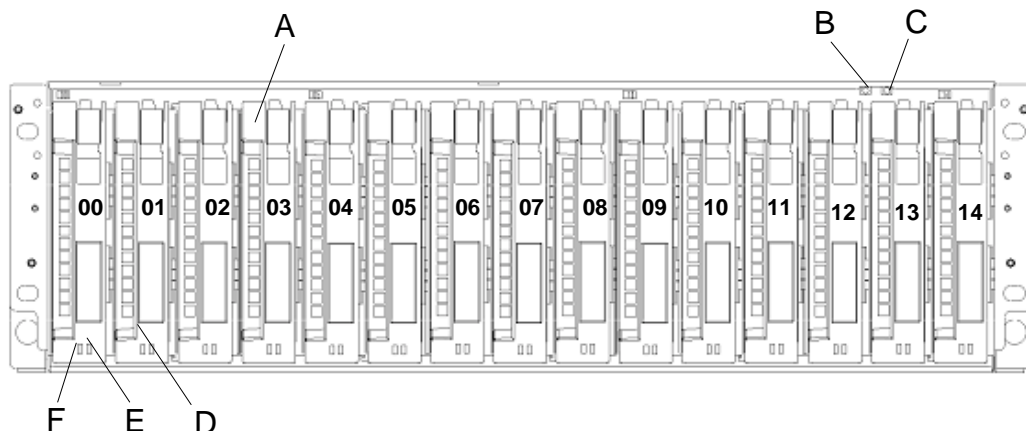

A	Tray Ejector	The ejector is used to secure and remove the disk module or dummy tray to the chassis.
B	POWER LED (green)	The POWER LED lights green if the AC power is supplied and the power switch is set to ON. The LED is off if the power switch is set to OFF.
C	SERVICE LED (orange)	<p>The SERVICE LED lights orange when the disk array unit encounters an error. The LED flashes during the self-test and initialization immediately after the power is turned on.</p> <p>The LED goes off when the disk array unit has started, and it is off while the disk array unit is operating normally.</p>
D	Disk module	<p>The dedicated tray containing the HDD (hard disk drive).</p> <p>The disk modules are installed in three slots from the left and bound as RAID level 5 (shipping default). The remaining twelve slots contain dummy trays.</p>
E	HDD READY LED (green)	<p>The HDD READY LED lights green while the disk module operates normally. The LED blinks when the disk module transfers data.</p> <p>The HDD READY LED blinks during the self-test or initialization just after power-on.</p>
F	HDD FAULT LED (orange)	The HDD FAULT LED lights at the occurrence of an error in the disk drive. The LED is off while the disk drive operates normally.

Figure 1-7. Front Chassis Features and Indicators (Bezel Removed)

Rear Chassis Features

Figure 1-8 shows the features and indicators located on the rear of the DAU.

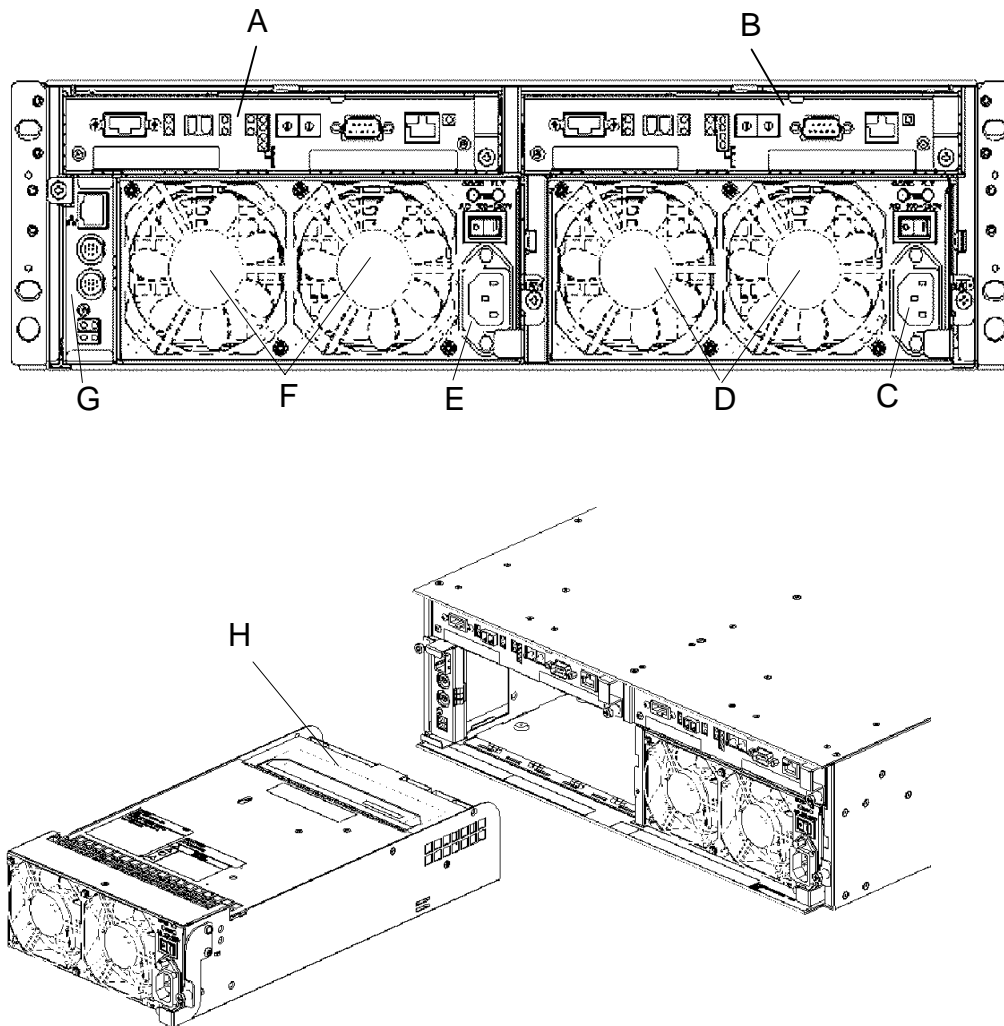

- A Controller (CONT1)
- B Controller (CONT0)
- C Power Supply (PS0)
- D Fans (FAN0)
- E Power Supply (PS1)
- F Fans (FAN1)
- G Service Processor (SVP)
- H Battery Backup Unit (PS1)

Figure 1-8. Rear Chassis Features

Power Supply

Figure 1-9 shows the features and indicators located on the rear of the power supply.

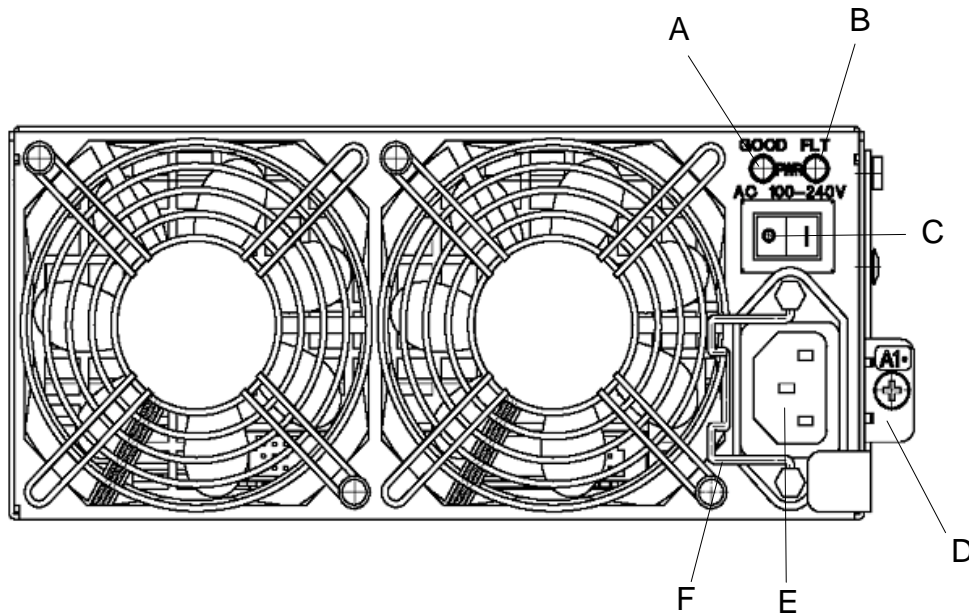

- | | | |
|---|-------------------------------|---|
| A | Power Good LED (Green) | The POWER GOOD LED lights green when the AC power is supplied to the disk array unit and the power switch is set to ON. The LED is off if the power switch is set to OFF or a fault occurs in the power supply. |
| B | Power Fault LED (Orange) | The POWER FAULT LED lights if a fault occurs in the power supply. |
| C | Power Switch | The power switch is used to turn the disk array unit power on or off. |
| D | Ejector | The ejector is used to eject the power supply from the DAU chassis. |
| E | Power Plug | The power plug supplies power to the disk array unit. Plug in one end of the attached power cord to this plug and plug the other end of the cord to the AC outlet of a voltage of 120VAC 50Hz or 60Hz. This disk array unit uses auto-sense power supplies for 100V - 240VAC (50/60Hz) operation.

The power cord shipped with the DAU is for 100-120VAC. If the disk array unit is used at a voltage other than 100-120VAC, prepare the proper cord for the voltage and current capacity for the unit. |
| F | Stopper (power cord retainer) | The stopper prevents the power cord from being removed unexpectedly from the power supply. |

Figure 1-9. Power Supply Features and Indicators

DAU Controller

Figure 1-10 shows the features and indicators located on the rear of the DAU controller.

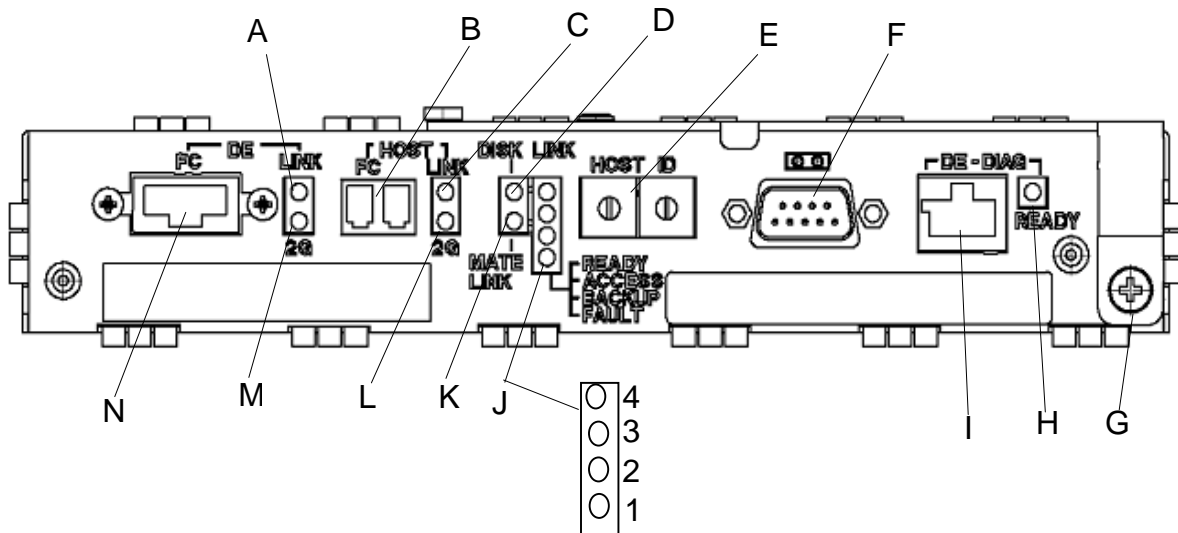

A	LINKUP LED (DE-LINK)	This LED lights green if the Disk Enclosure Fibre Channel (DE-FC) connector (FC port) becomes operable (linked). This LED is off during self-test or initialization, just after power-on.
B	FC Connector	Connection between fiber channel controller and the host (HOST-FC). This connector is used to connect the disk array unit to the basic processing unit (host).
C	LINKUP LED (HOST LINK)	This LED lights green while the FC interface with the host is operable.
D	LINKUP LED (DISK-LINK)	This LED lights green if the respective disk module becomes operable (links up). This LED is off during the self-test or initialization, just after power-on.
E	AL-PA switch	This switch sets the address of the disk array unit as a fiber channel device in the fiber channel loop. At shipment, the addresses of CONT0 and CONT1 are set to "00" and "01," respectively. Set AL-PA so that the address may not be the same as that of another fiber channel device in the same host FC loop.
F	RS-232C connector	The RS-232C connector is provided for maintenance of the disk array unit.
G	Ejector	This device is used to install and remove the controller.
H	DE-DIAG LED (green)	The DE-DIAG LED lights green when the controller is ready for diagnosis.
I	DE-DIAG connector	The DE-DIAG connector is provided to connect a cable to the Disk Enclosure (DE) for diagnosing (monitoring) functions in the DE..
J1	FAULT LED (orange)	The FAULT LED lights orange if a fault occurs in the controller.

J2	BACKUP LED (orange)	<p>This LED, when lit, shows that the battery backup unit is charged and on line to supply power to cache memory in the event of a power failure.</p> <p>Replacing the controller, power supply, and/or battery backup unit while the BACKUP LED is lit, loses the data in cache memory.</p> <p>The battery backup unit supplies power to the cache memory for a maximum of three days (72 hours in the full-charged condition). After this time period, cache data may be lost.</p>
J3	ACCESS LED (green)	The ACCESS LED blinks while the controller is in operation.
J4	READY LED (green)	The READY LED lights green while the controller operates normally. The LED blinks during the self-test or initialization, just after power-on.
K	LINKUP LED (MATE-LINK)	This LED lights green if the other controller in the DAU becomes operable (links up). This LED is off during the self-test or initialization, just after power-on.
L	HOST-2G LED	The HOST-2G LED lights green while the FC interface with host is operating at 2Gbps.
M	DE 2G LED	The DE 2G LED lights green while the FC interface with Disk Enclosure is operating at 2Gbps.
N	FC connector (for connection with disk enclosure) (DE-FC)	This connector is used to connect the Disk Array unit to the Disk Enclosure (DE).

Figure 1-10. Controller Features and Indicators

Battery Backup Unit

Figure 1-11 shows the battery backup unit.

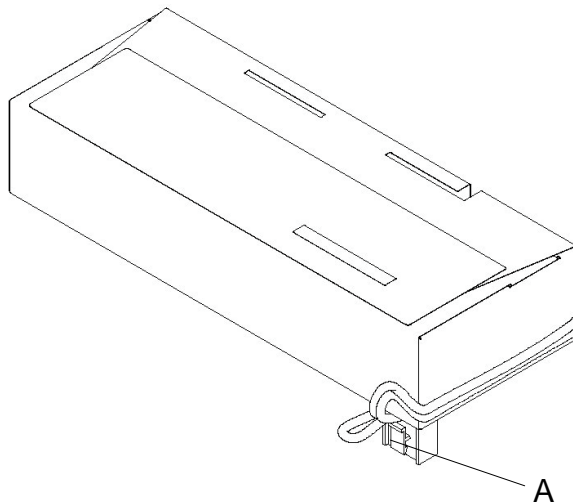

A Connector

This connector is used to connect the battery backup unit with the power supply.

Figure 1-11. Battery Backup Unit

SVP Service Processor

Figure 1-12 shows the features and indicators located on the rear of the SVp service processor.

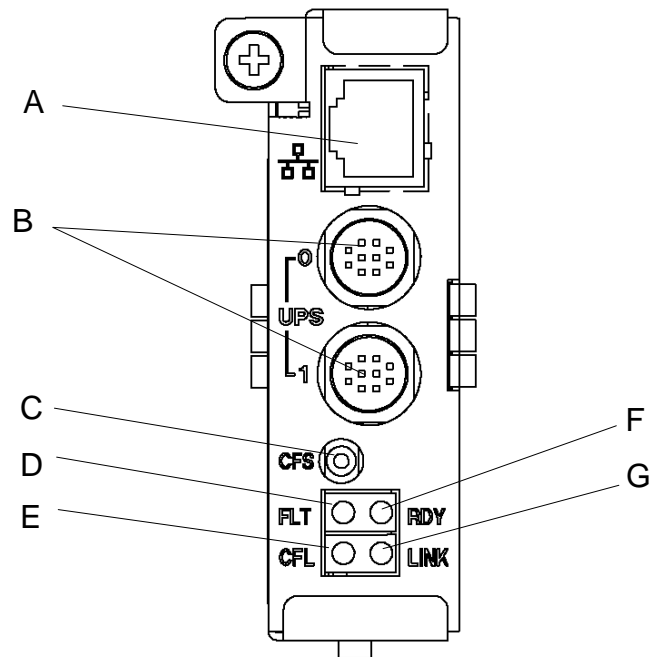

- | | | |
|---|---|--|
| A | Ether
(10/100BASE-T)
connector | (Ethernet connector) |
| B | UPS connector
(UPS0/UPS1
connector) | For the configuration in which the device receives AC power from UPS (uninterruptible power supply), the signal cable connector is used to connect the DAU with the UPS. |
| C | CACHE FLUSH
switch
(pushbutton
switch) | This switch, when pushed, saves the cache data to the disk. |
| D | FLT LED (FAULT
LED) | This LED, when lit, shows a fault occurred in the SVR.

When this LED flashes during the scheduled stop, the Write Back error has occurred. |
| E | CFL LED | This LED, when lit, indicates that data is being saved from the cache to the disk. |
| F | RDY LED
(READY LED) | This LED, when lit, shows the service processor (SVR) is operating in a normal state. |
| G | LINK LED (TX/RX
LED) | This LED lights green when transmission/reception of data is being transferred to and from a network. |

Figure 1-12. SVP Service Processor

Disk Enclosure Controller

Figure 1-13 shows the features and indicators located on the rear of the Disk Enclosure controller.

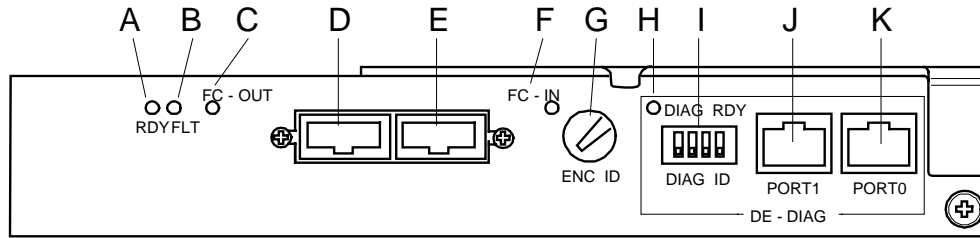

A	READY LED (green)	The READY LED lights green while the controller operates normally. The LED blinks during the self-test or initialization, just after power-on.
B	FAULT LED (orange)	The FAULT LED lights orange if a fault occurs in the controller.
C	FC-OUT LINKUP LED (2 nd DE LINK)	This LED lights green indicating the FC interface with a second DE is operable. A second DE is not currently available with the S1300 DAU.
D	FC connector (for connection with a 2 nd DE)	This connector is used to connect the Disk Enclosure (DE) with a second DE. A second DE is not currently available with the S1300 DAU.
E	FC connector (for connection with Disk Array Unit)	This connector is used to connect the Disk Enclosure (DE) with the Disk Array Unit.
F	FC-IN LINKUP LED (DAU LINK)	This LED lights green indicating the FC interface with the DAU is operable.
G	ENC ID Switch	This switch sets the ID address of the DE Controller. This switch must be set to 1 in the DE.
H	DE-DIAG LED (green)	The DE-DIAG LED lights green when the controller has a valid diagnostic connection to the DAU.
I	DIAG ID Switches	The four DIP switches are set to OFF (down) for the first DE.
J	DE-DIAG connector	The DE-DIAG connector is provided to connect a cable to a second DE for diagnosing (monitoring) functions in the second DE. A second DE is not currently available with the S1300 DAU.
K	DAU-DIAG connector	The DAU-DIAG connector is provided to connect a cable to the DAU for diagnosing (monitoring) functions in the DE.

Figure 1-13. Disk Enclosure Controller Features and Indicators

2

Setting Up The DAU

- Overview
- Selecting a Site
- Unpacking the DAU and Rack Mounting Hardware
- Rack-Mount Subsystem Assembly
- Connecting Disk Array Unit
- Connecting the Power Cords
- Connecting the DAU to Uninterruptible Power Supplies
- Powering On/Off
- Scheduled Stop Procedure

Overview

This chapter describes how to select a site, unpack the DAU and provides you with assembly information for preparing and mounting the DAU into a system rack. Also described are DAU to host cabling configurations, connecting the power cord(s), powering On/Off the DAU, and configuring the Fibre Channel address switches.

Selecting a Site

The DAU operates reliably in a typical office environment. Choose a site that is:

- Near grounded, three-pronged power outlets.

 **Note:** For the United States and Canada, this means a NEMA 5-15R outlets for 100-120 VAC or NEMA 6-15R outlets for 200-240 VAC. For other international sites, this means three-pronged power outlets applicable for the electrical code of the region.

WARNING

Be sure the power service connection is through a properly grounded outlet.

CAUTION

Be sure that the power plug from each of the power supplies is plugged into the same common ground power outlets.

- Clean, dust-free, and well ventilated. Front and rear ventilating openings kept free of obstructions. Away from sources of heat, vibration or physical shock.
- Isolated from strong electromagnetic fields and electrical noise produced by electrical devices (such as air conditioners, large fans, large electric motors, radio and TV transmitters, and high-frequency security devices)
- Spacious enough to provide at least five inches (13 centimeters) behind the DAU and three inches (eight centimeters) on each side of the DAU for proper cooling, airflow, and cable clearance.

 **Note:** Provide an additional five inches (13 centimeters) behind the DAU to facilitate changing the self-contained hot-swap power supply unit.

-
- Easily accessible for DAU maintenance and installation of DAU upgrades.

Unpacking the DAU and Rack Mounting Hardware

WARNING

The DAU weighs approximately 80 lbs (36 kg). If the DAU contains numerous optional devices and rack mount parts, it will weigh more. To avoid personal injury, make sure you have someone help you lift or move the DAU.

Although the DAU and rack mount kit are inspected and carefully packaged at the factory, damage may occur during shipping. Follow these steps for unpacking.

1. Visually inspect the shipping containers; notify your carrier immediately of any damage.
2. Place the DAU shipping container on a flat, clean, stable surface. Carefully remove the DAU and set it aside. If the DAU is damaged, notify your server representative. See Figure 2-1, A.
3. Carefully remove the parts in the Accessories Kit and verify the contents. See Figure 2-1, B through I and Table 2-1. If parts are missing or the hardware is damaged, notify your server representative.
4. Save the containers and packing materials for any future reshipment.

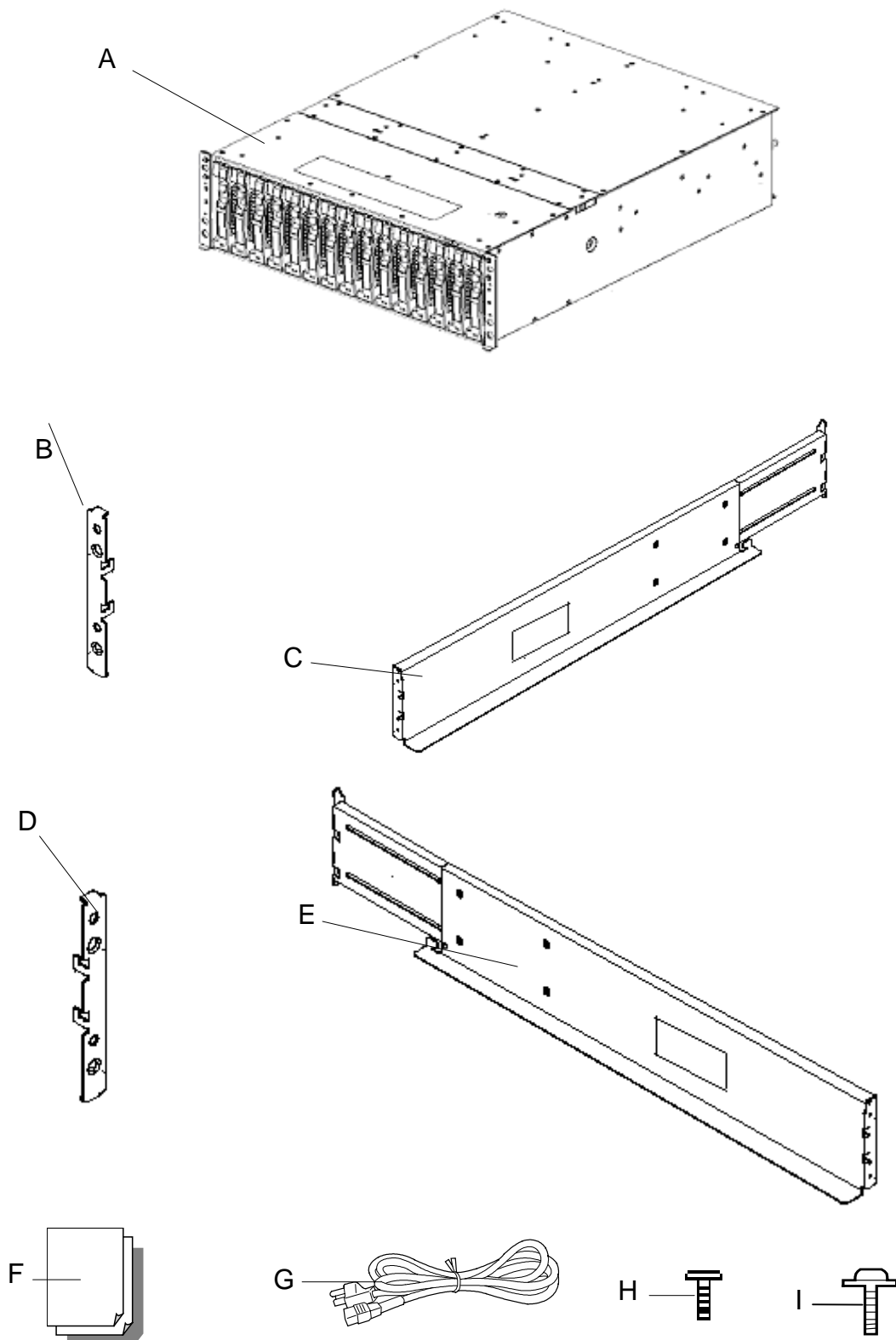

Figure 2-1. DAU and Rack Mount Kit Parts

2-4 Setting Up The DAU

Table 2-1. DAU and Rack Mount Parts

Reference	Description	Reference	Description
A	Disk Array Unit (DAU)	F	User's Guide (located on CDRom)
B	Left Rail Support Hook	G	Power Cords (2)
C	Left Rail	H	Countersunk Head Screws (4)
D	Right Rail Support Hook	I	M5 Screws (4)
E	Right Rail		

Rack-Mount Subsystem Assembly

Before You Begin

Before you begin, please review the following cautions, warnings, and general guidelines.

- Avoid excessive vibration and shock. Dropping an electronic component can cause serious damage.
- Do not disconnect or remove parts other than those specified in the procedure.
- Do not touch I/O connector pins.
- All screws are Phillips-head, unless otherwise specified.

Static Precautions

An electrostatic discharge (ESD) can damage disk drives, option boards, and other components. You can provide some ESD protection by wearing an antistatic wrist strap attached to chassis ground when handling DAU components.

Electronic devices can be easily damaged by static electricity. To prevent damage, keep them in their protective packaging when they are not installed in the DAU.

Installing the Rails

 **Note:** In the following procedure the left rail is shown as viewed from the front of the rack. Right rail installation procedures also apply to installing the right rail.

1. Rail support hooks are marked (L) for the left hook and (R) for right hook. With the left rail support hook (L) facing towards the inside of the cabinet, hang the top tab of the rail support hook on the square hole of the rack front rail to which the DAU will be mounted. Be sure the counter-sunk holes in the rail support hook are centered within the square holes of the rack front vertical rail. Also, the hook projections on the rail support hooks should be facing upwards. See Figure 2-2.

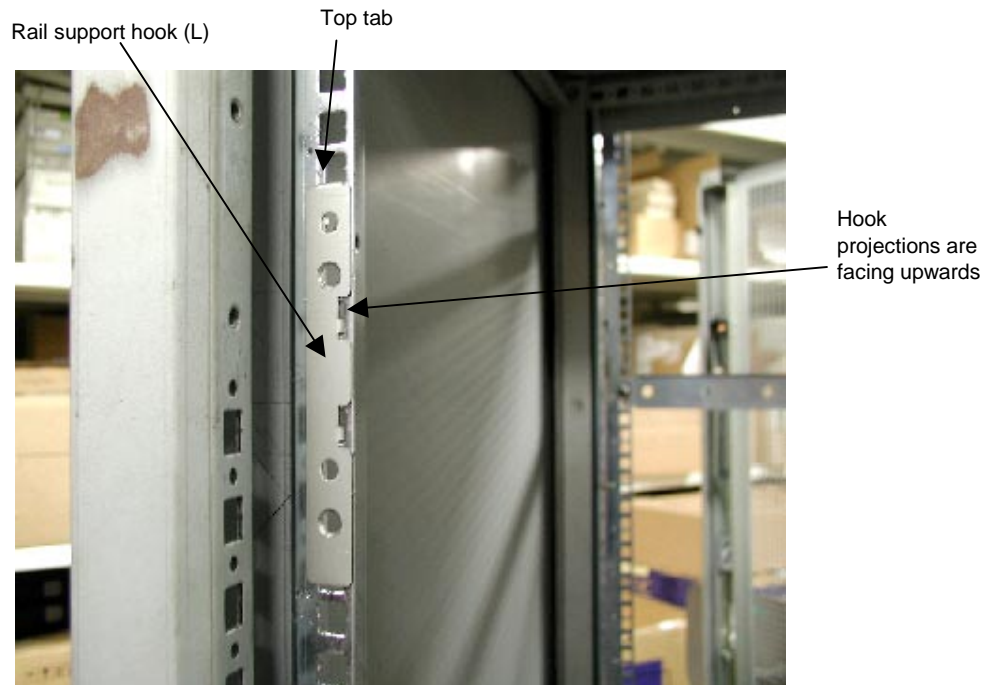

Figure 2-2. Positioning the Left Rail Support Hook

-
2. While holding the left rail hook in position with your left hand, engage the cutout at the front of the left rail into the rail support hooks protruding through the cabinet vertical rail. The front of the left rail should be positioned behind the cabinet front vertical rail and resting on the two left rail hooks. See Figure 2-3.



Figure 2-3. Positioning the Left Rail

3. Secure the left rail to the rail support hook with two countersunk head screws. See Figure 2-4.



Figure 2-4. Securing the Left Rail

4. At the rear of the rack, slightly loosen the four countersunk head screws in the side of the left rail. These screws must not be removed. See Figure 2-5.



Figure 2-5. Tightening the Countersunk Head Screws

5. Pull the inner rail toward you and engage the upper and lower rail tabs into the rectangle holes. While holding the inner rail, screw the mounting bolts (M5 bolts) into the threads of the inner rail. See Figure 2-6.



Figure 2-6. Securing the Inner Rail

-
- Firmly tighten the four countersunk head screws loosened in Step 4. See Figure 2-7.

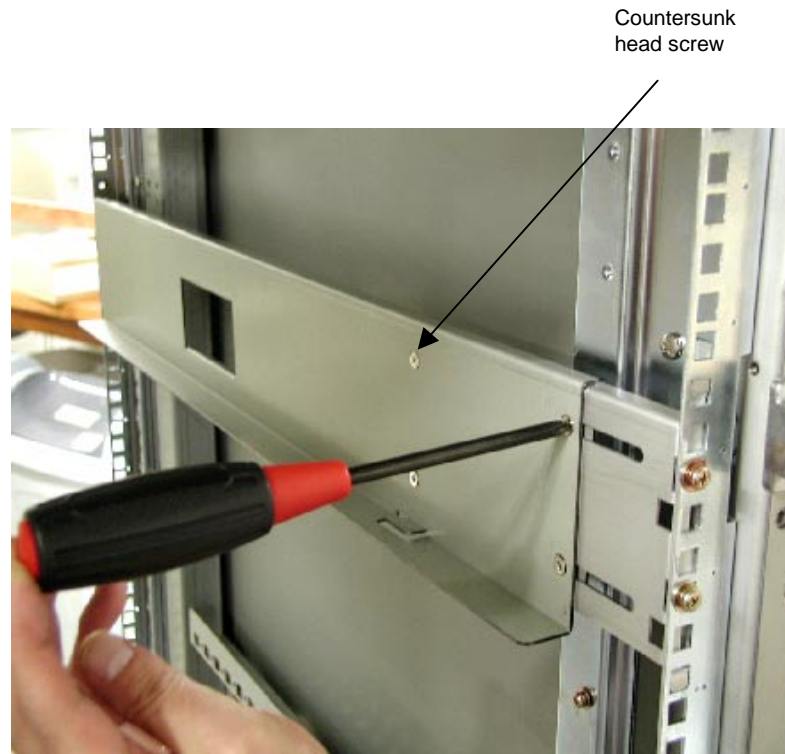

Figure 2-7. Tightening the Countersunk Head Screws

- Repeat steps 1 through 6 and install the right rail.

Installing the DAU into the System Rack

⚠ WARNING

To reduce the risk of personal injury or damage to the equipment, a minimum of two people **MUST** lift the DAU into the rack. The DAU weighs 80 lbs (36 kilograms). If the unit is to be loaded above chest level, a third person must assist in aligning the rails while the other two support the unit.

- With one person grasping each side of the DAU, carefully align the DAU to the rack's slide rails and slide the DAU into the rack.
- Secure the DAU to the system rack with two M5 screws. See Figure 2-8.

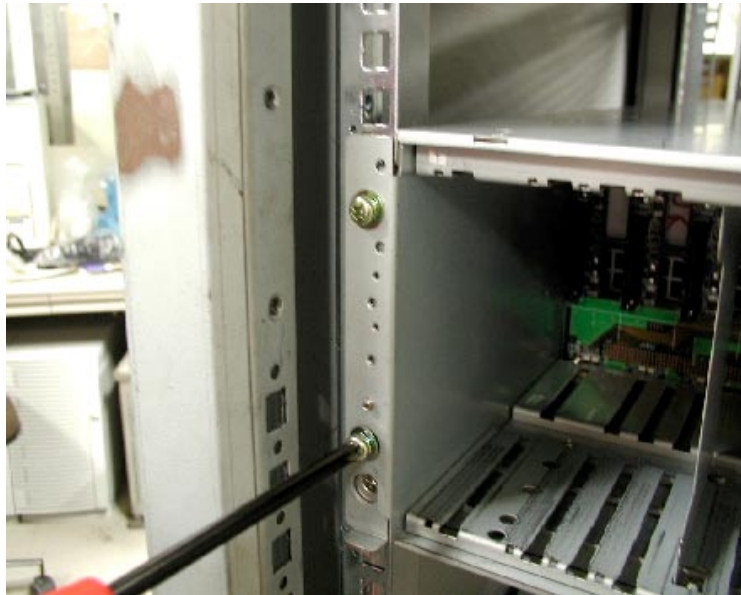

Figure 2-8. Securing the DAU to the System rack

Connecting Disk Array Unit

The following sections provide information for connecting the DAU to the Host server and the optional disk enclosure. Figure 2-9 show a typical DAU installation and includes cabling for the optional disk enclosure.

Host Connection

1. Connect the disk array unit with the host using the two supplied FibreChannel cables. Push the connector at either end of the cable into the FC connector (HOST-FC) of the disk array controller (CONT0) until a click is heard. The FC cable has the same connectors at both ends. Either connector may be connected to the controller. See Figure 2-9.
2. Connect the other end of the FibreChannel cable to the connector of FibreChannel controller installed in the host system. Connect the second FibreChannel cable between the second disk array controller (CONT1) and the host system.

Disk Enclosure Connection

1. Connect either end of the HSSDC-HSSDC cable into the DE-FC connector (CONT0) on the disk array unit until a click is heard. The HSSDC-HSSDC cable has the same connectors at both ends. Either connector may be connected to the controller. Connect the other end of the HSSDC-HSSDC cable into the FC-IN connector on adapter 0 (ADP0) of the disk enclosure until a click is heard. See Figure 2-9.
2. Similarly, connect the second HSSDC-HSSDC cable into DE-FC connector (CONT1) on the disk array unit until a click is heard. Connect the other end of this HSSDC-HSSDC cable into the FC-IN connector on adapter 1 (ADP1) of the disk enclosure until a click is heard.

3. Connect either end of the DE diagnosis cable into the DE-DIAG connector of the controller (CONT0) until a click is heard. The DE diagnosis cable also has the same connectors at both ends. Either connector may be connected to the controller. Connect the other end of the DE diagnosis cable into the PORT0 connector on adapter 0 (ADP0) of the disk enclosure until a click is heard. See Figure 2-9.
4. Similarly connect either end of the second DE diagnosis cable into the DE-DIAG connector of the controller (CONT1) until a click is heard. Connect the other end of the DE diagnosis cable into the PORT1 connector on adapter 1 (ADP1) of the disk enclosure until a click is heard.

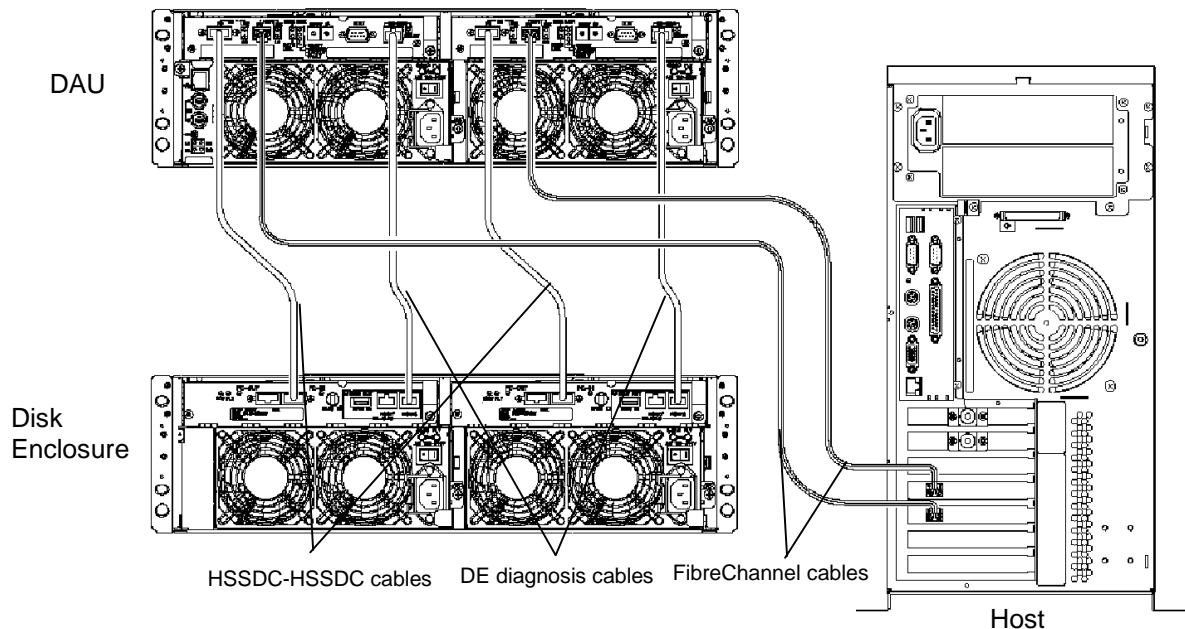

Figure 2-9. Connecting the Disk Array Unit

Connecting the Ethernet Cable

To enable configuration changes and fault monitoring for the disk array unit by the management software "NEC Storage Manager" through Ethernet, the LAN cable must be connected.

Connect an Ethernet cable to the Ethernet connector (modular jack) on the LAN card.

Connect the host system on which the management software "NEC Storage Manager" is installed.

Contact your service provider to configure the LAN address.

Connection Notes

Connection Cable

To connect the host bus adapter of the host system or the FC-AL switch with the disk array unit, be sure to use the NEC-specified FC cable.

To connect the disk array unit with the additional disk enclosure, be sure to use the DE cable provided with the additional disk enclosure, or the NEC-specified DE cable.

Cable Length Limitations

FC optical cable for operating the host interface at 1Gbps: Up to [500 m]

FC optical cable for operating the host interface at 2Gbps: Up to [300 m]

Settings Topology and Data Transfer Rate

A topology and data transfer rate must be set correctly in accordance with the host bus adapter to be connected or the connection mode of the FC-AL switch.

Factory-set topology and data transfer rate:

Topology: FC-AL Data transfer rate: 2Gbps

You can change the topology and data transfer rate of the FC connector for the host bus adapter by changing the DIP switch settings on the controller. Refer to Appendix A in this guide.

Setting DAU and Disk Enclosure Switches

 **Note:** The controller IDs of disk array unit (CONT0 or CONT1) must correspond to that of and that of disk enclosure (CONT0 or CONT1).

The AL-PA switch sets the address of the disk array unit as a fiber channel device in the fiber channel loop. At shipment, the addresses of DAU controllers CONT0 and CONT1 are set to "00" and "01," respectively. Set the AL-PA so that the address is not the same as that of another fiber channel device in the same host FC loop. See Figure 1-10, E for the location of the controller AL-PA switch. Refer to Appendix A for additional AL-PA switch settings.

The Enclosure ID (ENC ID) switch on each adapter of the additional disk enclosure are factory-set to "1". See Figure 1-13, H. Make sure both ENC ID switches are set to "1".

The DIAG ID switches on both adapters of the additional disk enclosure are factory-set to "0". Make sure that both DE-DIAG ID switches are set to "0". See Figure 1-13, J.

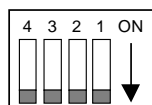

DE-DIAG ID = "0"

Connecting the Power Cords

The DAU contains two 450-watt power supplies. The power supplies are designed for automatic sensing of 115 or 230 VAC power, eliminating the need for a line voltage selector switch. The power supplies operate at a frequency of 50/60 Hz. With two power supplies installed, if one fails, the second power supply will ensure the DAU continues to operate without interruption.

Connect each power cord as follows.

1. Check that the power switch on the disk array unit and those on the host system, host bus adapter, and FC-AL switch are all set to OFF. See Figure 2-10.

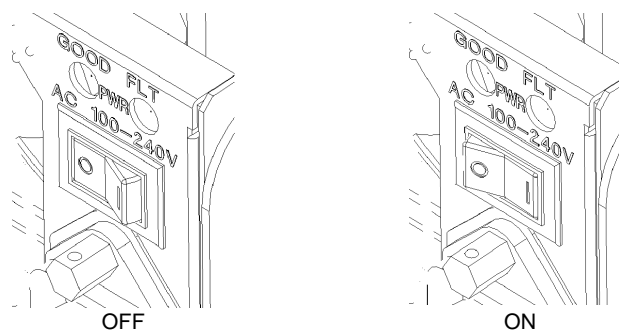

Figure 2-10. Power Supply Switch

2. Insert the power cord into the power plug on the power supply, and secure the power cord with stopper. See Figure 2-11. Repeat this step on the second power supply.

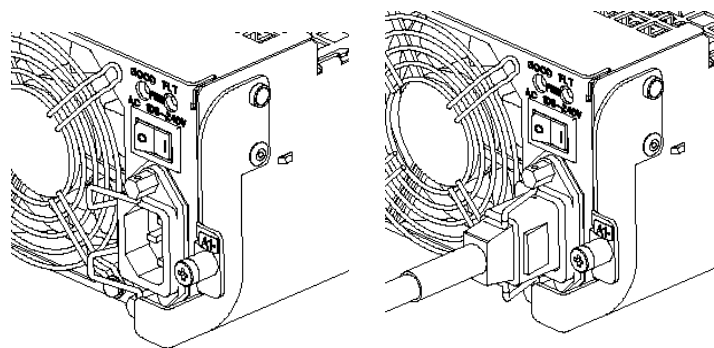

Figure 2-11. Connecting the Power Cord to the Power Supply

3. Plug the male end of the power cords into NEMA 5-15R outlet for 100-120 VAC or NEMA 6-15R outlet for 200-240 VAC.

If the power cords supplied with the DAU are not compatible with the AC outlet in the region, obtain a suitable power cord that meets the following criteria.

- The power cord must be rated for the available AC voltage and have a current rating that is at least 125% of the current rating of the DAU.
- The power cord connector that plugs into the wall outlet must be terminated in a grounding-type male plug designed for use in the region. It must have certification marks showing certification by an agency acceptable in the region.
- The power cord connector that plugs into the DAU must be an IEC- type CEE-22 female connector.
- The power cord must be less than 1.8 meters (6.0 feet) long.

 **WARNING**

The DAU shipped with a power cord for each power supply. Do not attempt to modify or use the supplied AC power cord if it is not the exact type required.

Connecting the DAU to Uninterruptible Power Supplies

Figure 2-12 shows the connection of a DAU to uninterruptible power supplies (UPS). When the DAU is connected to a UPS, the system continues to operate in the event of an unexpected power failure or momentary AC power fluctuation.

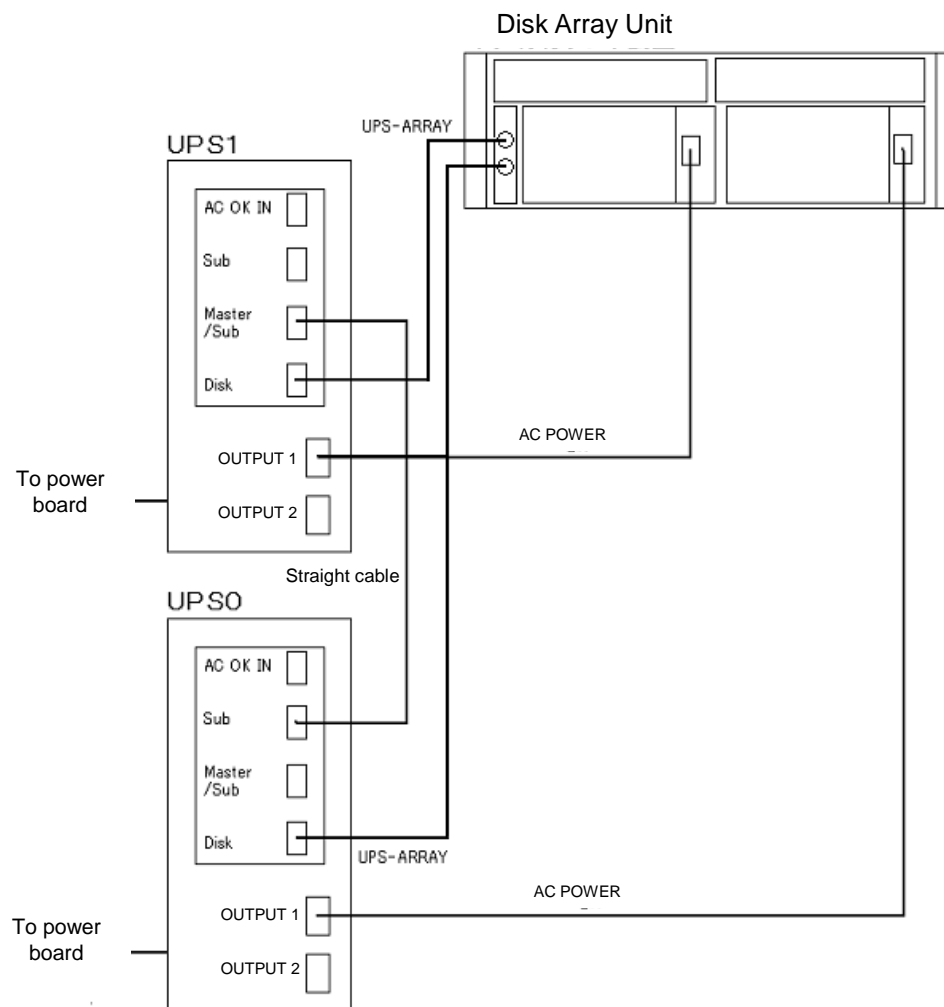

Figure 2-12. Connection the DAU to a UPS

Cable Dressing

All the interface and power cables connected to the rear of the DAU should be dressed and tie wrapped. Use special care not to kink or sharply bend the Fibre Channel cables as they are easily damaged.

Route the cables so that they do not contact the door and guide rails on both sides of the system rack. Also, ensure that there is some slack on all the cables and especially the power cord to prevent it from being disconnected from the DAU when the unit is pulled forward in the rack.

Powering On/Off

This section describes the sequence of steps for powering the disk array unit on or off.

CAUTION

Carelessly turning power on or off may cause some data to be lost, some software to operate incorrectly, or cause damage to the unit.

Turning On AC Power

 **Note:** Before turning on the AC power, check for loose disk modules by ensuring each module is fully seated into the disk bay.

1. Turn on the disk enclosure connected with the disk array controller (if applicable), before turning on the disk array unit.
2. Turn on the power switches located on the rear panel of each power supply.
3. Confirm that the POWER LED (green) on the front panel of the DAU is on. See Figure 1-7. Also check that the POWER LED located on each power supply on. See Figure 1-9.
4. The disk array unit performs a self-test and initialization immediately after the power is turned on. When the self-test and initialization complete and the disk array unit become ready, the READY LEDs (green) on the controllers in the disk array unit stop flashing and enter the on-state. Confirm that the controller READY LEDs are on. See Figure 1-10, J4 for the location of the controller LEDs.

 **Note:** The disk array unit may take as long as four minutes (at maximum) to start.

- Power on the host system.

Turning Off AC power

1. Power off the host system.

The host writes cache data to the disk array unit.

2. Confirm that the cache data from the host is successfully written into the disk array unit. To do this, check the DISK ACCESS LEDs located on the rear panel of each controller. If the DISK ACCESS LEDs are flashing, data remains in cache memory of disk array unit. Writing cache data onto disk could take as long as 5 minutes. See Figure 1-10, J3 for the location of the DISK ACCESS LED.
3. Turn off the AC power to the DAU. A power switch is located on the rear panel of each power supply. See Figure 1-9.



CAUTION

When the DAU power is turned off before the cache data is written to disk, the BACKUP LED on the controller is lit and the disk array unit enters the backup mode. If the backup mode lasts for more than three days (in the full-charged condition), the cache data may be lost. Therefore, if the BACKUP LED is lit, immediately turn on the disk array unit. Since the data write is an automatic process, check the data is completely written to the disk and then turn off the power.

4. Turn off AC power to the disk enclosure (if installed).



CAUTION

Turn off the power of host system, disk array unit, and disk enclosure in that order. Turning off the power of disk enclosure first may lose the data.

Scheduled Stop Procedure

Perform the following procedure to be absolutely sure that cache data has been completely written to disk before you power off the DAU.

- 1.** Power off the host system.

The host writes cache data to the disk array unit.

- 2.** Press and hold the CACHE FLUSH pushbutton (scheduled stop switch) located on the SVP Service Processor until the CFL LED flashes or is continuously lit (for at least two seconds). See Figure 1-12 for the location of the CACHE FLUSH pushbutton and the CFL LED.
- 3.** Release the CACHE FLUSH pushbutton when the CFL LED starts to flash or is continuously lit. The CFL LED continually flashes as data is being transferred from the cache to the disk.
- 4.** Before turning off the disk array unit, make sure that the CFL LED is continuously lit. Once the CFL LED is continually lit, the cache flush operation has completed.
- 5.** Power off the DAU.

3

Adding and Removing Components

- General Information
- Static Precautions
- Preparing Your DAU for Upgrade
- Accessing the DAU
- Hard Disk Drives
- Replacing a Controller Module
- Replacing a SVP Service Processor
- Replacing the Power Supply
- Replacing the Battery Backup Unit

General Information

 **Note:** Disk Array Unit (DAU) removal and replacement procedures documented in this chapter also apply to the Disk Enclosure (DE).

WARNING

Before doing the procedures in this manual, make sure that your DAU is powered off and unplug the AC power cords from the back of the chassis. Failure to disconnect power before opening your DAU can result in personal injury and equipment damage.

CAUTION

Operating your DAU with the cover removed can damage your DAU components. For proper cooling and airflow, always replace all covers before powering on your DAU.

WARNING

The SVP Service Processor contains a lithium battery. Do not remove the lithium battery. Contact your sales agent. The lithium battery may explode when it is brought close to heat or fire or immersed in water. Dispose of lithium batteries as required by local ordinance or as normal waste if no local ordinance exists. Keep all batteries away from children.

Static Precautions

An electrostatic discharge (ESD) can damage disk drives, the DAU board, and other components. You can provide ESD protection by wearing an antistatic wrist strap attached to chassis ground when handling DAU components.

Electronic devices can be easily damaged by static electricity. To prevent damage, keep them in their protective packaging when they are not installed in your DAU.

Preparing Your DAU for Upgrade

Depending on the upgrade, you may need one or more of the following tools:

- Phillips screwdriver
- Small needle nose pliers
- Pen or pencil
- ESD workstation or antistatic wrist strap (recommended)

The following components may be added or removed from the DAU without removing the DAU from the system rack.

- Hard disk drives
- Power supplies
- Controller Units and cache memory
- SVP Service Processor
- Battery Backup Units

Accessing the DAU

WARNING

To reduce the risk of personal injury or damage to the equipment, a minimum of two people **MUST** lift the DAU out of the rack. The DAU weighs 80 pounds (36.4 kilograms).

CAUTION

To make the DAU lighter and more manageable and to protect your hard disk drives from damage, consider removing the hard disk drives in the DAU before removing the DAU from the rack.

To access the DAU in the system rack:

1. Open the front and rear doors to the system rack.
2. Terminate all applications and power down the Host and DAU following procedures described in Chapter 2 of this guide.
3. Unlock the front bezel using the security key and remove the bezel. The front bezel can be removed by releasing the lock with the accessory key. Grasp the sides of the bezel and pull the bezel toward you.

To secure the DAU into the system rack:

1. Install and lock the front bezel.
2. Close the front and rear doors of the system rack.

Hard Disk Drives

Your DAU supports two types of Fibre Channel hard disk drive modules. The Fibre Channel drives must use the industry standard 40-pin Single Connector Attachment (SCA) connector. The drives used in the DAU are one of these two types:

- 36GB disk modules (10,000RPM) and (15,000RPM)
- 73GB disk modules (10,000RPM)
- 146GB disk modules (10,000RPM)

Installing or Swapping a Hard Disk Drive Modules in a Hot-swap Bay

This procedure describes installing a new drive or swapping out a faulty drive from one of the fifteen disk drive bays. The Fibre Channel drives use the industry standard 40-pin Single Connector Attachment (SCA) connector. Your DAU shipped from the factory with dummy drive carriers installed in all empty drive bay positions. These dummy drive carriers have gray ejector buttons. Drive carriers that have a disk drive installed in them have blue ejector buttons.

 **Note:** To order a disk with a carrier, contact your sales representative or dealer.

- If installing new drives, follow an installation scheme starting with the left-hand drive. Fill the bays left to right. It is recommended that hot spare disk drives be installed in the right-most positions.
- Hard disk drives may be removed or installed without powering down the DAU.
- If an individual Fibre Channel drive fault LED (amber light) is on steadily, this indicates that the drive has been flagged as faulty. Follow the procedure described in this section to remove the faulty drive and swap in a good one.

 **Note:** ESD can damage disk drives, boards, and other parts. This DAU can withstand normal levels of environmental ESD while you are hot-swapping Fibre Channel hard drives. However, we recommend that you do all procedures in this chapter only at an ESD workstation or provide some ESD protection by wearing an antistatic wrist strap attached to chassis ground—any unpainted metal surface—on your DAU when handling parts.

 **CAUTION**

Drive manufacturers caution against moving a disk drive that is still spinning because of possible damage to the drive.

After you determine which drive has been flagged as faulty, the procedure is the same to swap a drive or to install one for the first time.

Installing or Swapping a Hard Disk Drive

1. Access the DAU by following procedures previously described in “Accessing the DAU” found earlier in this chapter.
2. If installing a new hard disk drive module for the first time, perform the following procedure; if swapping out an existing drive, go the Step 4.
3. Remove the dummy drive carrier from the Fibre Channel hard disk drive bay in which you are installing the new disk drive. See Figure 3-1. Pull the ejector on the dummy carrier assembly toward you to release the lock. A click is heard when the lock is released. Once the lock is released, hold the handle and pull the dummy carrier assembly out of the drive bay. Go to step 5.

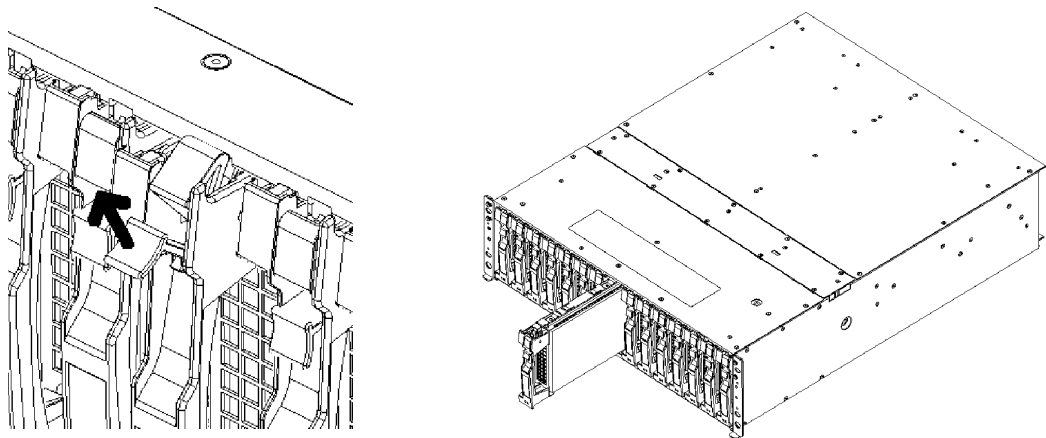



Figure 3-1. Removing a Dummy Hard Disk Drive Dummy Tray

 **Note:** The dummy carriers are provided to maintain proper cooling. Leave the dummy carriers in unused slots. (Keep all removed dummy carriers for future use.)

4. If swapping a hard disk drive, remove its carrier from the Fibre Channel hard disk drive bay by performing the following procedures:

! **CAUTION**

Depending on the drive fault, the drive may be still spinning when you remove it. Follow the next steps exactly when removing drives.

- Pull the blue ejector on the carrier assembly toward you to release the lock. A click is heard when the lock is released. Once the lock is released, hold the handle and pull the carrier out of the bay far enough to disengage the drive connector from the backplane. Wait 30 seconds until the drive spins down.
 - Remove the drive carrier from the drive bay.
5. Remove the replacement drive carrier from its protective wrapper, and place it on an antistatic surface. The hard disk drive has been already installed into the carrier at the factory.

! **CAUTION**

Observe static precautions. Use an antistatic wrist strap.

6. Affix a drive number label to the front of the hard disk drive. See Figure 1-7.
7. Record the drive model and serial numbers in the equipment log.
8. Install the drive carrier with drive into the drive bay as follows:
- With the ejector of the disk module opened, engage the guides on the top and bottom faces of the disk module with the guide grooves on the disk enclosure and insert the disk module into the drive bay. See Figure 3-2.

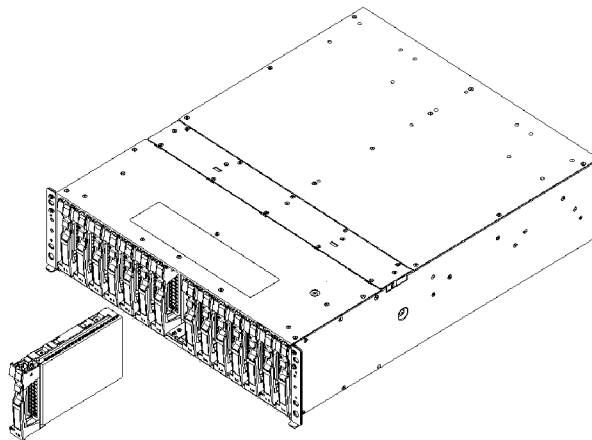

Figure 3-2. Installing the Drive Module into the Drive Bay

- Push the drive carrier into the drive bay until it docks with the Fibre Channel backplane connector. Push on the carrier until the drive is completely seated into the Fibre Channel backplane connector.

- Push downward on the ejector button to lock the drive in place. See Figure 3-3.

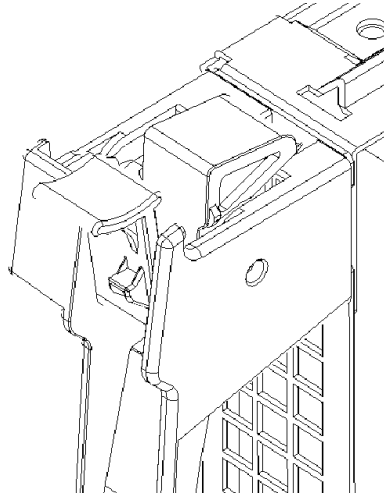

Figure 3-3. Locking the Ejector Button

9. Install and lock the front bezel.
10. Close the front door on the system rack.

Replacing a Controller Module

If a controller is defective, the SERVICE LED on the disk array unit front panel lights orange (see Figure 1-7). In addition, the FAULT LED on the controller lights orange (see Figure 1-10, J1). The defective controller may be replaced with the power of the disk array unit remaining ON.

Replacement Procedure

1. Identify the defective controller module. The FAULT LED on the controller rear panel lights orange.
2. Disconnect the host and disk enclosure (if applicable) cables connected to the controller.
3. Loosen a screw securing the ejector of the controller module to the chassis. See Figure 3-4.

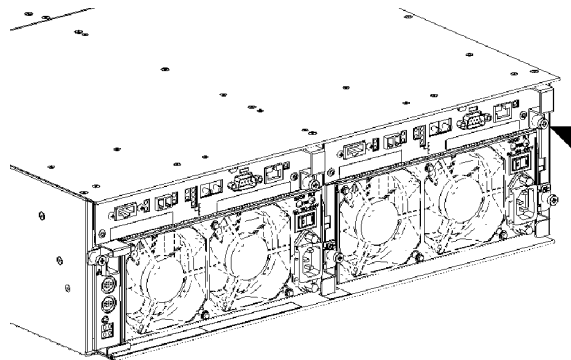

Figure 3-4. Loosening the Controller Ejector Screw.

- Put your finger within the protrusion (shown in the figure) of the ejector, and pull it the ejector toward you to release the controller module. See Figure 3-5

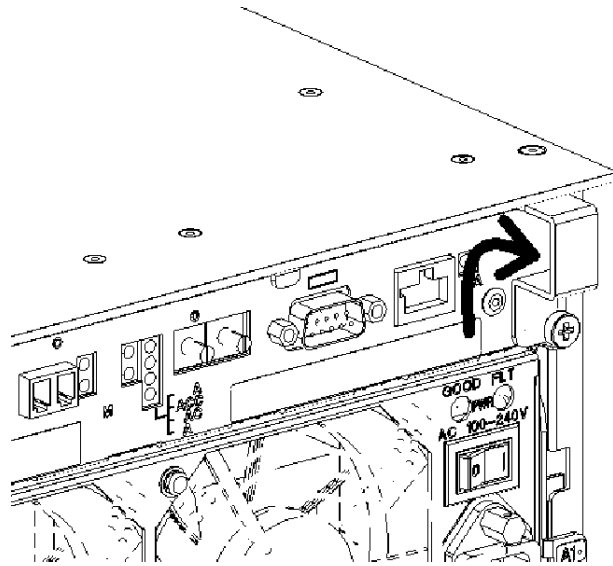

Figure 3-5. Grasping the Controller Module Ejection Lever.

- Open the ejector by pulling it towards the left. See Figure 3-6.

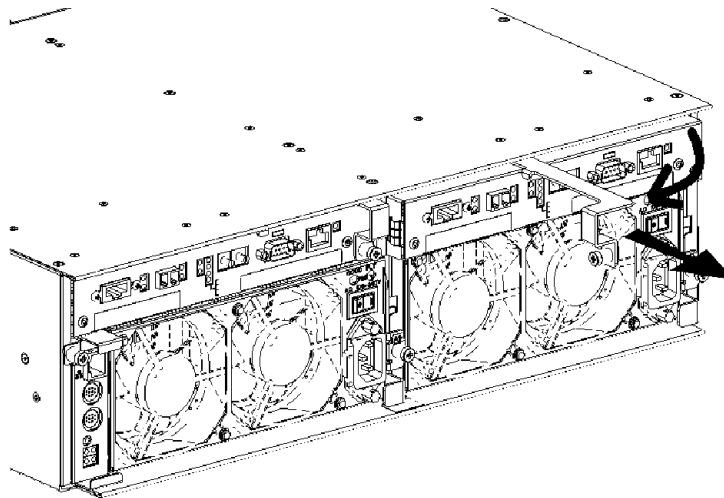

Figure 3-6. Removing the Defective Controller module.

- Pull the controller out of the chassis, turn it over and set it on a clean surface.
- Remove the cache memory stick(s) from the controller. The cache memory will be used in the replacement controller. See Figure 3-7.

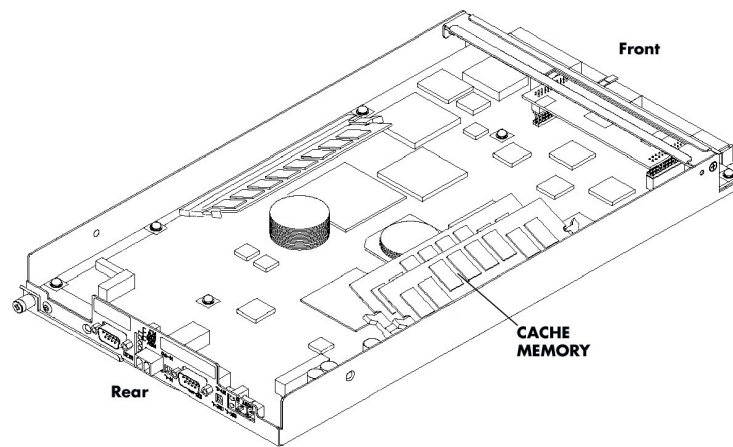

Figure 3-7. Controller Cache Memory Location

⚠ WARNING

The controller module may be hot. Handle carefully.

8. Set the DIP switch and AL-PA switch on the new controller module to the same settings as the controller you removed. See the section “Setting the AL-PA Switch” in Chapter 2 of this guide.
9. Install the cache memory sticks removed in Step 8 into the replacement controller. See Figure 3-7.
10. Open the ejectors of the controller, insert the controller into the chassis. See Figure 3-8.

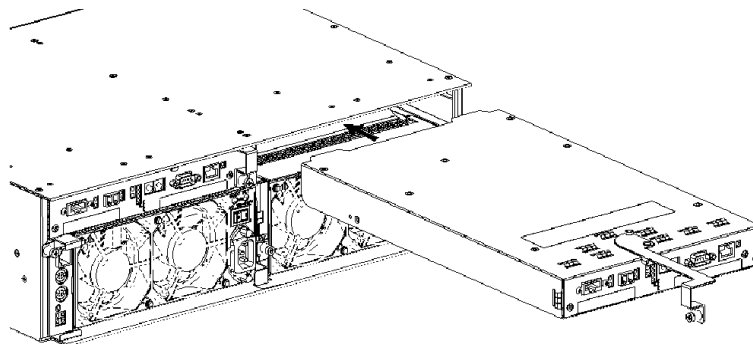

Figure 3-8. Installing a Replacement Controller.

11. Insert the controller as far as it will go into the chassis, and close the ejector. See Figure 3-9.

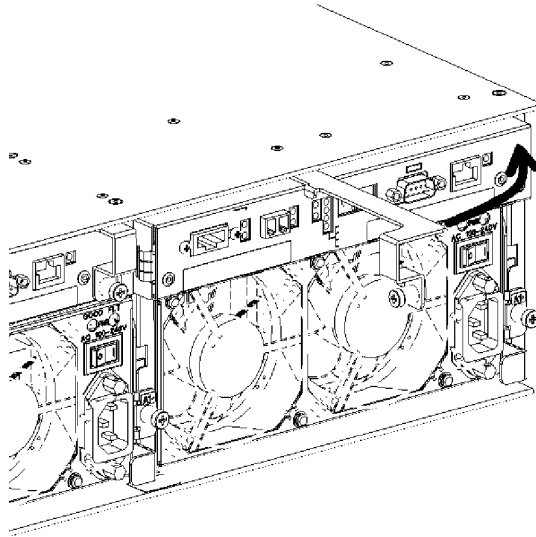

Figure 3-9. Closing the Ejector.

- 12.** Push in on the ejector until the controller is firmly seated in the chassis. See Figure 3-10. Secure the ejector with the screw previously removed. See Figure 3-4.

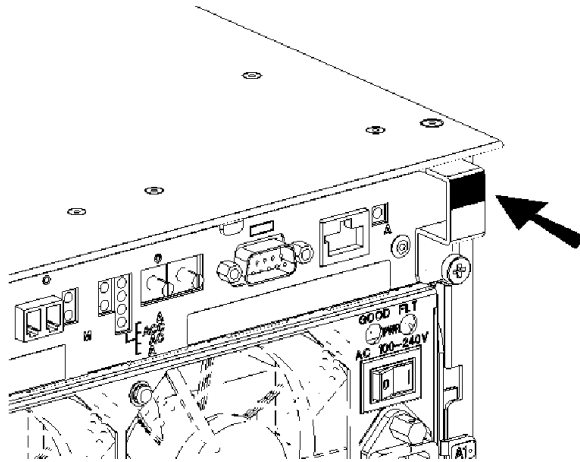

Figure 3-10. Securing the Ejector.

- 13.** Connect the host and disk enclosure (if applicable) cables to the controller.

Replacing a SVP Service Processor

WARNING

The SVP Service Processor contains a lithium battery. Do not remove the lithium battery. Contact your sales agent. The lithium battery may explode when it is brought close to heat or fire or immersed in water. Dispose of lithium batteries as required by local ordinance or as normal waste if no local ordinance exists. Keep all batteries away from children.

If a SVP service processor is defective, the SERVICE LED on the disk array unit front panel lights orange (see Figure 1-7). In addition, the FAULT LED on the SVP service processor lights orange (see Figure 1-12, D). The defective SVP service processor may be replaced with the power of the disk array unit remaining ON.

Replacement Procedure

1. Disconnect the cables connected to the SVP service processor.
2. Loosen a screw securing the SVP service processor to the chassis. See Figure 3-11.

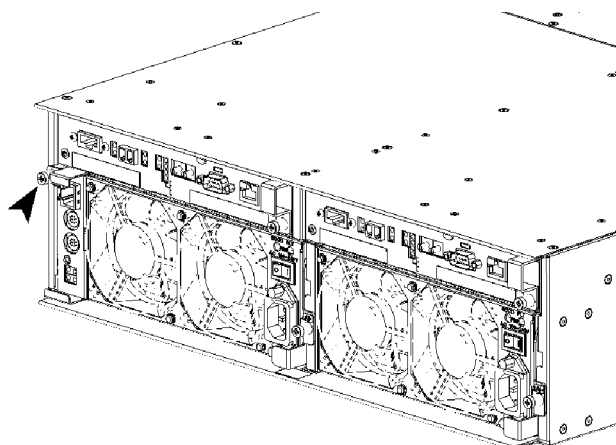

Figure 3-11. Loosening the SVP Service Processor Ejector Screw.

3. Grasp the points shown in Figure 3-12 and pull the SVP Service Processor toward you. Remove the SVP Service Processor.

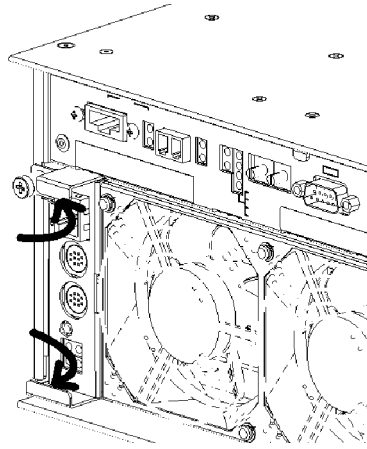

Figure 3-12. Grasping the SVP Service Processor.

4. Install the replacement SVP Service Processor. See Figure 3-13.

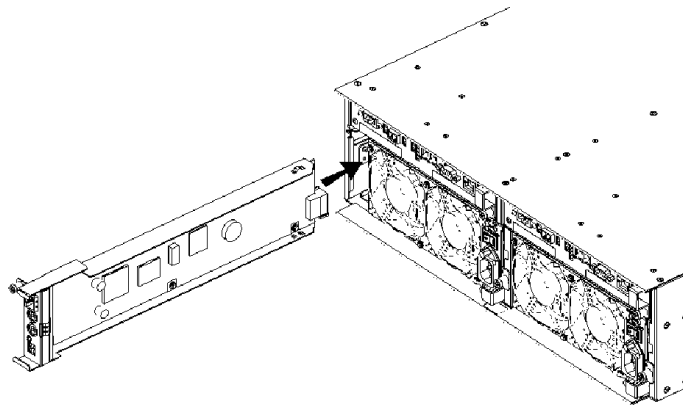

Figure 3-13. Installing the Replacement SVP Service Processor.

5. When the SVP is in position where the finger on the right side of the SVP service processor is as shown in Figure 3-14, push the projections at the top and bottom of the SVP Service Processor until it is firmly seated in the chassis.

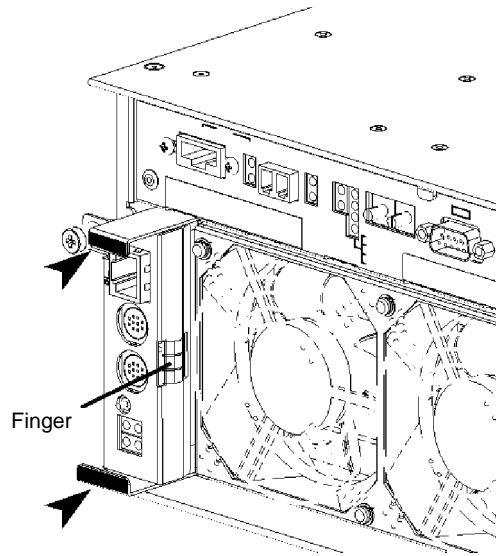

Figure 3-14. Completing the Installation of the SVP Service Processor

6. Secure the SVP service processor with the screw previously removed. See Figure 3-15.

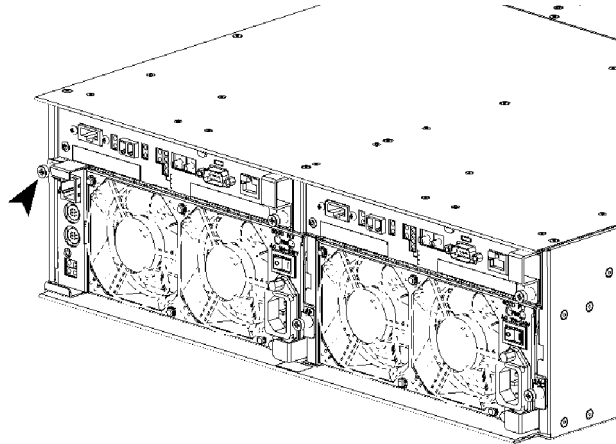



Figure 3-15. Securing the SVP Service Processor.

7. Connect the cables to the SVP Service Processor.

Replacing the Power Supply

If a power supply is defective, the SERVICE LED on the disk array unit front panel lights orange (see Figure 1-7). In addition, the POWER FAULT LED on the power supply lights orange (see Figure 1-9, B). The defective power supply may be replaced with the power of the disk array unit remaining ON.

 **Note:** Complete the power supply replacement within five minutes. If the time exceeds five minutes, the protective feature of the disk array unit triggers the shutdown sequence.

Replacement Procedure

1. Identify the faulty power supply with the "POWER FAULT" LED lit.
2. Turn off the power switch of the faulty power supply. See Figure 3-16.



Figure 3-16. Powering off the Power Supply

3. Unlatch the power cord retainer clip as shown in Figure 3-17 to release and unplug the power cord.

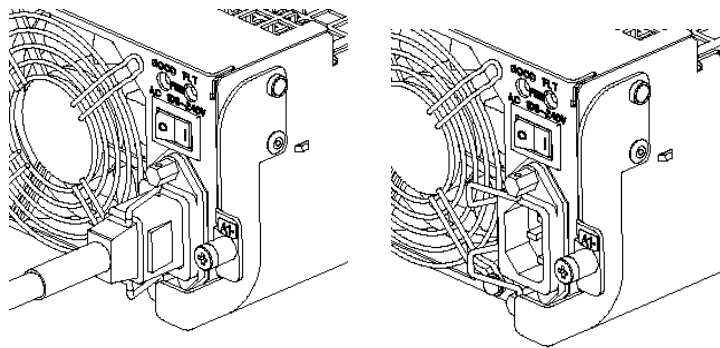

Figure 3-17. Removing the Power Cord

4. Loosen the ejector set screw of the faulty power supply. See Figure 3-18.

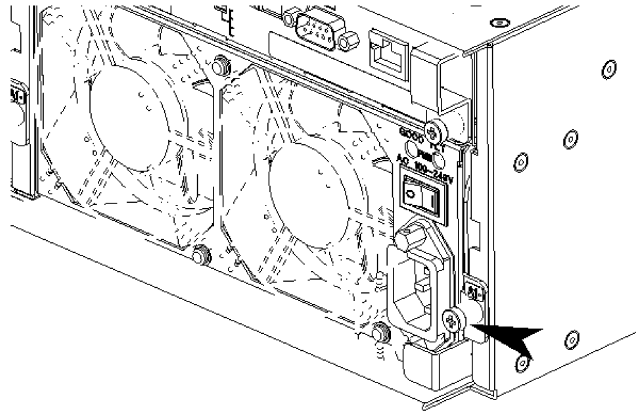

Figure 3-18. Loosening the Power Supply Ejector Set Screw

5. Put your finger on the protrusion of the ejector, and pull the ejector towards you. See Figure 3-19.

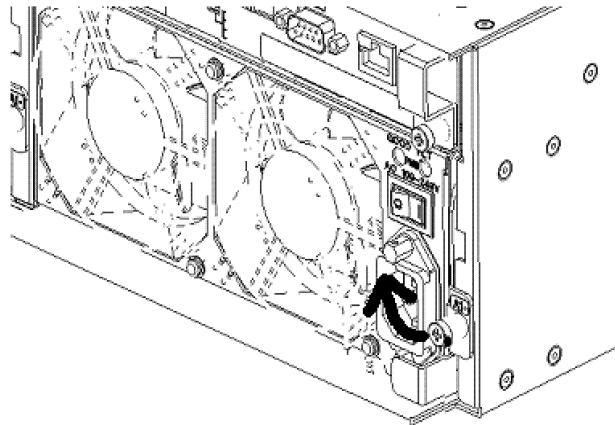

Figure 3-19. Releasing the Power Supply Ejector.

6. Once the ejector is released, remove the power supply. See Figure 3-20.

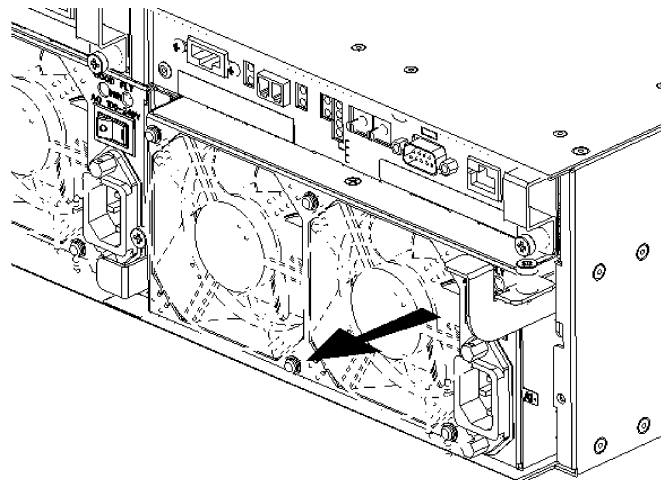

Figure 3-20 Removing the Power Supply.

-
7. Remove the crest fastener securing the battery press fitting to the power supply. Then remove the battery press fitting. See Figure 3-21.

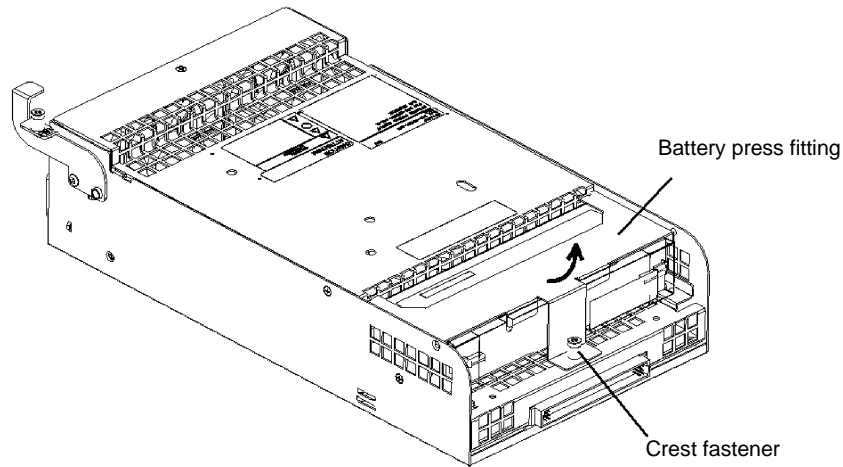

Figure 3-21. Removing the Battery Press Fitting

8. Disconnect the battery backup cable from the power supply and remove the battery backup unit. See Figure 3-22.

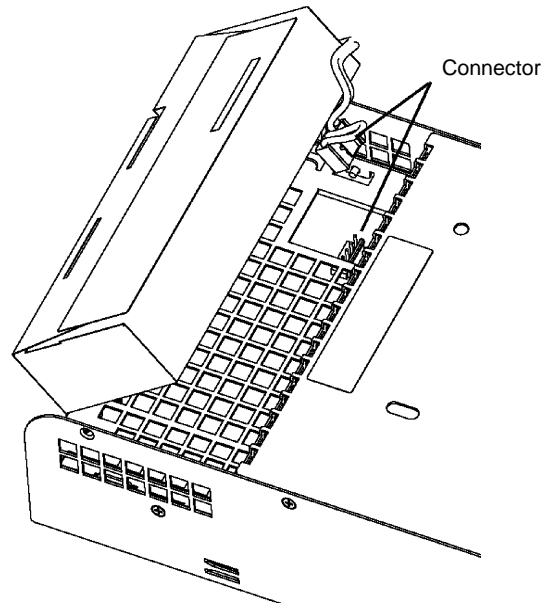

Figure 3-22. Removing the Battery Backup Unit

9. Connect the battery backup unit cable to the replacement power supply. Place the battery backup unit into the supply so that the battery label faces upwards. See Figure 3-23.

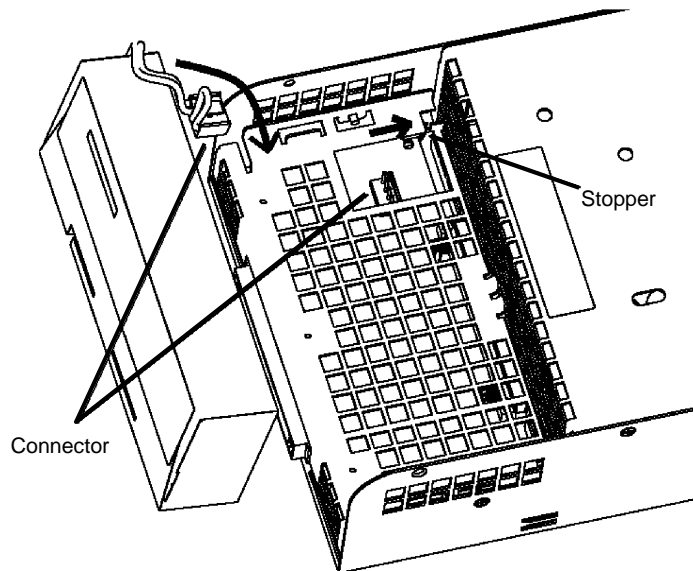

Figure 3-23. Installing the Battery Backup Unit into the Replacement Power Supply

10. Install the battery press fitting, previously removed, into the replacement power supply. Insert the rear tabs of the battery press fitting into the slots behind the battery backup unit. Insert the front tabs of the battery press fitting into slots on the battery backup unit. See Figure 3-24.

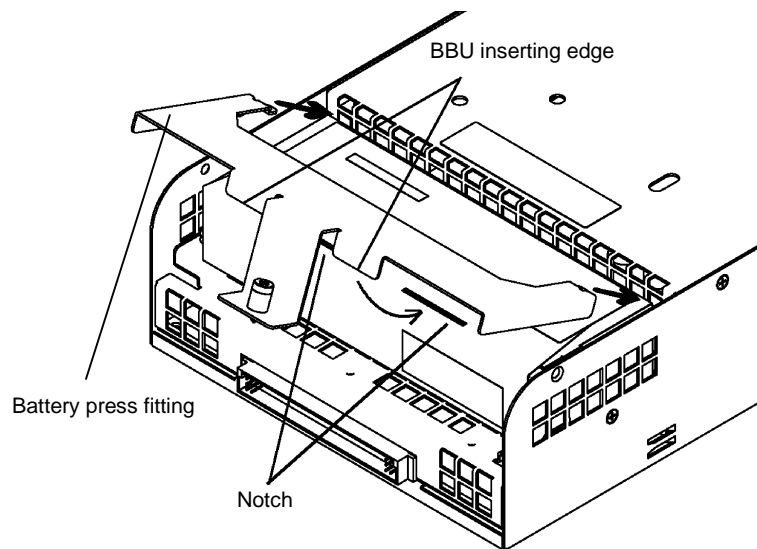

Figure 3-24. Installing the Battery Press Fitting.

11. Secure the crest fastener to the power supply. See Figure 3-25.

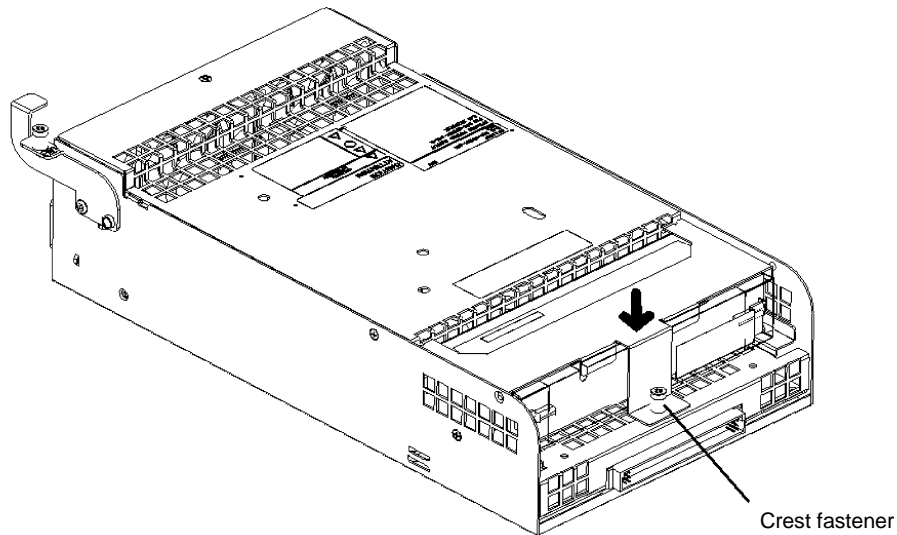

Figure 3-25. Securing the Crest Fastener.

12. Ensure the power switch of the replacement power supply is in off position and the power cord is not plugged in the power connector.
13. Ensure the power supply ejector is in the open position and insert the replacement power supply into the slot until it is firmly seated in the chassis. See Figure 3-26.

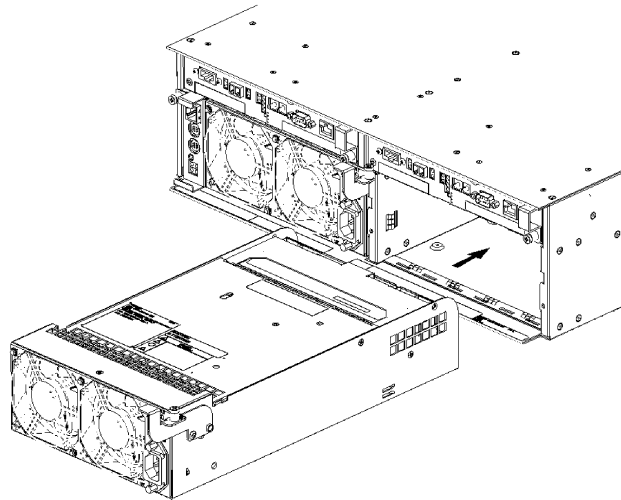

Figure 3-26. Installing the Replacement Power Supply.

-
- 14.** Push in on the ejector until the power supply is firmly seated in the chassis. See Figure 3-27.

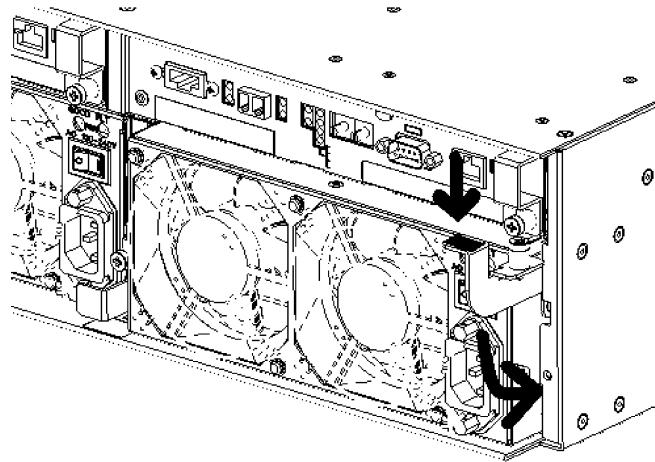

Figure 3-27. Closing the Power Supply Ejector.

- 15.** Secure the ejector with the set screw. See Figure 3-28.

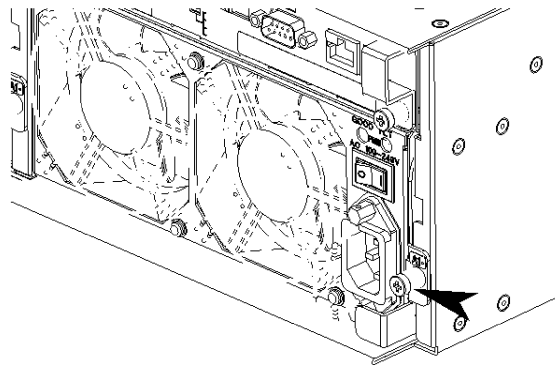



Figure 3-28. Securing the Power Supply Ejector.

- 16.** Plug the power cord in the connector on the power supply, and secure the power cord with the power cord retainer clip. Turn on the power switch.

Replacing the Battery Backup Unit

If a battery backup unit is defective, the SERVICE LED on the disk array unit front panel lights orange (see Figure 1-7). In addition, the POWER FAULT LED on the power supply containing the defective battery backup unit lights orange (see Figure 1-9, B). The defective battery backup unit may be replaced with the power of the disk array unit remaining ON.

 **Note:** Complete the power supply replacement within five minutes. If the time exceeds five minutes, the protective feature of the disk array unit triggers the shutdown sequence.

Replacement Procedure

1. Remove the power supply in which the defective battery backup unit is installed by following procedures described earlier in this chapter.
2. Remove the defective battery backup unit following procedures described in “Removing a Power Supply” found earlier in this chapter.
3. Install the replacement battery backup unit into the power supply following procedures described earlier in this chapter.

4

Maintenance and Troubleshooting

- Introduction
- Static Precautions
- Routine Maintenance
- Cleaning
- Initial DAU Startup Problems
- Troubleshooting
- LED Indicators
- SERVICE LED: On / FLT LED: Off
- Troubleshooting Flowcharts
- Media Errors on a Rebuilt Disk
- Temporary Degrade and Rebuild (Phoenix Feature)

Introduction

This chapter provides information on maintaining your DAU. This chapter also helps you identify and solve problems that may occur during initial installation of the DAU or while using your DAU.

Static Precautions

An electrostatic discharge (ESD) can damage disk drives, option boards, and other components. You can provide some ESD protection by wearing an antistatic wrist strap attached to chassis ground when handling system components.

Electronic devices can be easily damaged by static electricity. To prevent damage, keep them in their protective packaging when they are not installed in your system.

Routine Maintenance

Maintenance is the key to obtaining trouble-free operation of your DAU. To keep your DAU operating flawlessly proper care and maintenance checks must be performed periodically. For proper care of the DAU, refer to the "Cleaning" subsection that follows.

It is also recommended that you make backup copies of your valuable data stored in hard disks of the DAU on a regular basis. Also, inspect all cabling and replace any damaged cables connected to the DAU.

Cleaning

The DAU requires cleaning on a regular basis and especially if operating in a dusty environment.

WARNING

Before doing the procedures in this manual, make sure that your DAU is powered off and unplug the AC power cords from the back of the chassis. Failure to disconnect power from your DAU can result in personal injury and equipment damage.

CAUTION

Do Not use volatile solvents such as paint thinner and benzene to clean your DAU. These chemicals can damage the surface and color of the DAU external surfaces.

The interior of the DAU and all the power receptacles, cables, and connectors on its rear panel must be kept dry. Do not moisten them with any liquid.

Wipe the outside surface of the DAU cabinet, all power cord plugs, and dust from around the rear fan exhaust opening with a clean dry soft cloth.

If stains remain on the outside surfaces of the cabinet, use the following guidelines:

1. Power off the DAU and unplug all power cords and interface cables.
2. Rub off stains on surfaces by using a slightly dampened cloth soaked in a mild detergent. Do not use solvents or strong abrasive cleaners on any part of the unit.
3. After the stains are removed use a cloth soaked in plain water to remove any residue.
4. Wipe the DAU dry.

Initial DAU Startup Problems

Incorrect installation or configuration usually causes problems that occur at initial system startup. Hardware failure is a less frequent cause. If you have problems during initial system startup, check the following:

- Is the DAU power cords properly connected and plugged into a NEMA 5-15R outlet (100-120 VAC) or a NEMA 6-15R outlet (200-240 VAC)?
- Is AC power available at the outlets?
- Is the power LED on the front panel of the DAU lit?
- Are all interface cables correctly connected and secured?

If the above items are all correct, but the problem persists, refer to the "Troubleshooting" section that follows.

Troubleshooting

Table 4-1 summarizes problems that may develop during operation of the DAU and lists in sequential order suggested corrective actions.

Table 4-1. Problems and Solutions

Symptom	Reason	Solution
The POWER LED (green) does not light if the power switch is turned on.	The power cable is not connected.	Check the connection of the power cables after setting the power switch to OFF.
	The AC power (100 – 240 VAC) is not supplied.	Check whether 100 – 240 VAC \pm 10% (50/60 Hz) is supplied.
The LINKUP LED (green) of the disk array controller connected via the FC cable does not go on.	The FC cable is connected incorrectly.	Insert the connector of the FC cable until a click is heard. Connect the FC cable correctly according to procedures in Chapter 2.
	The length of the FC cable exceeds the rating value.	Maximum FC cable length is 300m.
	The setting of the FibreChannel controller is not correct.	Provide the proper setting referring to the user's manuals of the FibreChannel controller, host unit, and those of added peripherals.
The host system cannot recognize the disk array unit.	The used FibreChannel controller is unavailable for the disk array unit.	Use the FibreChannel controller available for the disk array unit. Contact your sales agent if unknown.
	The FC cable is not connected correctly.	Connect the FC cable correctly according to procedures in Chapter 2.
	Each AL-PA must be unique. The same AL-PA is specified in duplicate.	See Chapter 2 "Setting the AP-PA Switch."
	The setting of FibreChannel controller is incorrect.	Set it correctly according to the user's manuals of the FibreChannel controller, the host system, and additionally installed peripherals.
	The FibreChannel controller is unavailable for the disk array unit.	Use the FibreChannel controller available for the disk array unit. Contact your sales agent if unknown.
	The power is turned off or the reset button on the host system is pressed with the ACCESS LED (green) being on.	Contact your service agent.
	The LDN of the disk array unit is not assigned.	Assign the LDN appropriately using the "NEC Storage Manager" or contact your service agent.

LED Indicators

If the disk array unit is defective, the SERVICE LED on the disk array controller lights orange and the LED specific to the defective unit also lights orange.

Table 4-2 shows the relationship between the LED indicating the occurrence of a fault and the defective unit.

Table 4-2. LED Indicators

LED indication	Defected unit
The HDD FAULT LED on a specific disk module is lit orange.	The disk module with the FAULT LED lit is defective.
The FAULT LED of one of the controllers is lit orange.	The controller with the FAULT LED lit is defective.
The POWER FAULT LED on one of the power supplies is lit orange.	The power supply with the FAULT LED lit is defective. The battery backup with in the power supply could also be defective.
The FAULT LED of the SVP is lit orange.	The SVP with the FAULT LED lit is defective.
The FAULT LED of the SVP Service Processor is flashing orange. (Scheduled stop failed.)	The controller with the FAULT LED on or a disk module is probably defective. Check if another FAULT LED is on.

SERVICE LED: On / FLT LED: Off

When the SERVICE LED located on the front panel is lit, but none of the module FLT LEDs are lit, the disk array unit may have entered into one of the following states.

- The battery backup unit is being charged.

When the battery backup unit is completely charged, the SERVICE LED goes off. Whether the battery backup unit is being charged can be judged from the Subsystem Status displayed on the maintenance terminal (NEC Storage Manager or MSMGR).

- The LED for the faulty module is defective.

FAULT is displayed for the faulty part on the maintenance terminal (NEC Storage Manager or MSMGR) or the maintenance terminal.

- The logical drive is being restored.

When a logical drive is completely rebuilt, the SERVICE LED goes off. You can check the status of the rebuild with the NEC Storage Manager or MSMGR.

Troubleshooting Flowcharts

Use the following troubleshooting flowcharts to assist you in diagnosing problems experienced during DAU startup or when adding or removing the components documented in Chapter 3.

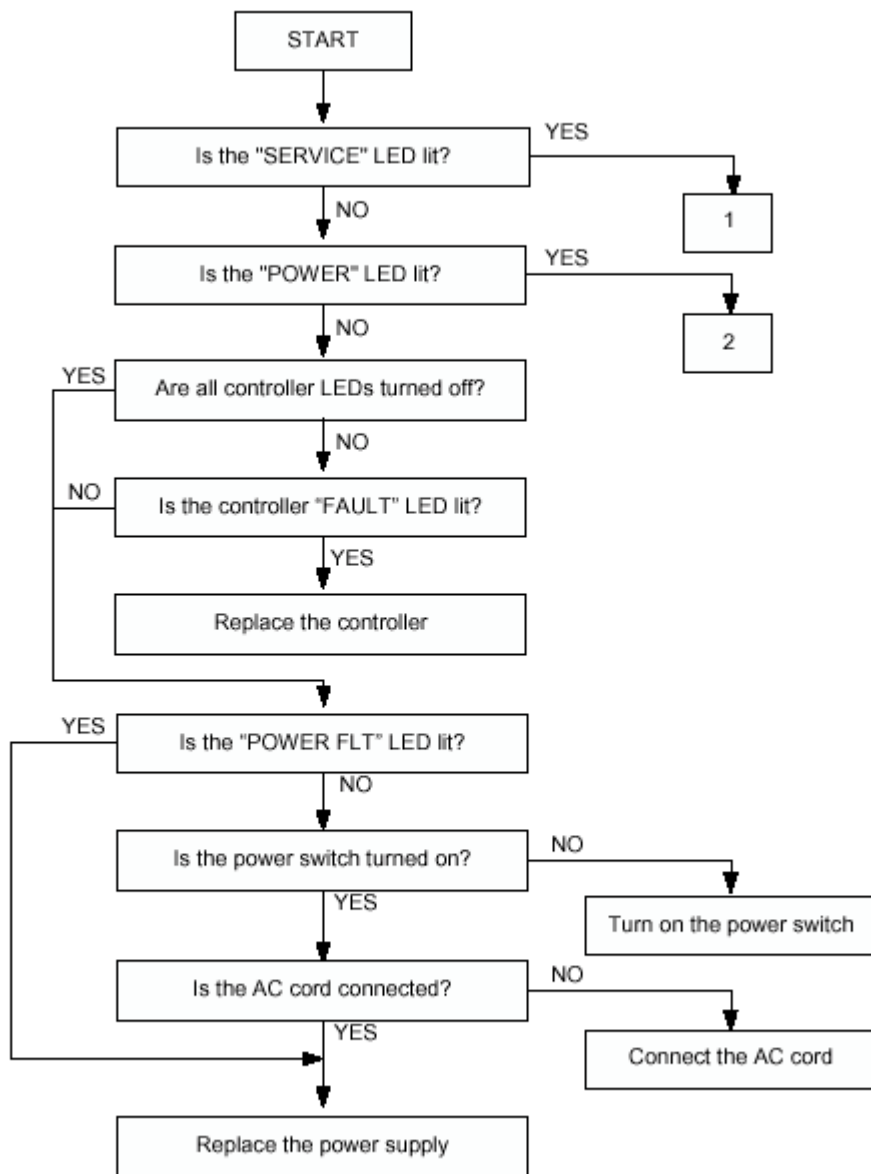

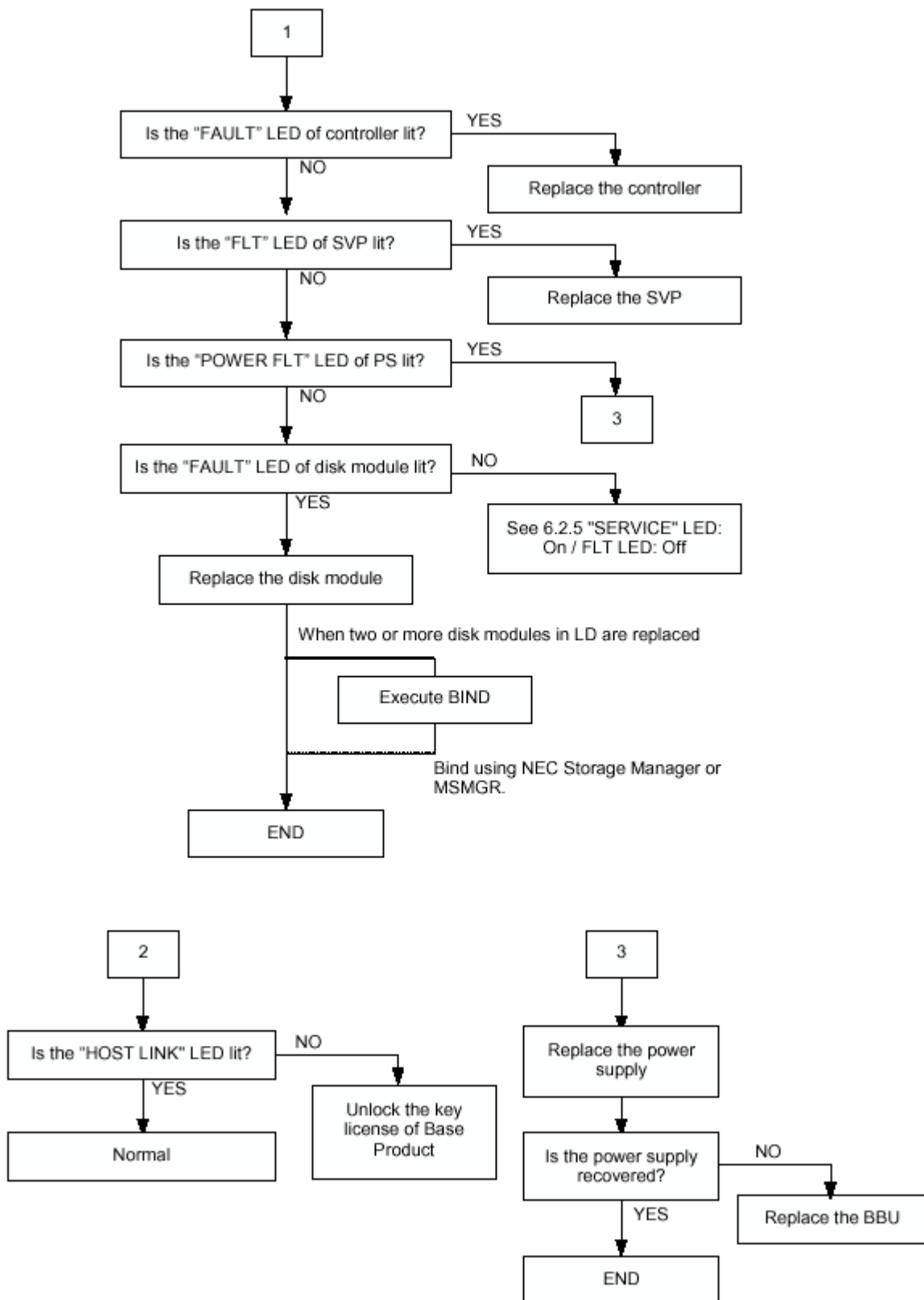

Media Errors on a Rebuilt Disk

When a media error occurs on the disk being rebuilt, note the block address of the disk and regenerate the remaining data area (partial rebuild). When the command is issued for the block, the sense code (04/90/2x) is reported. Since the data in the block has been lost, the following steps must be executed to restructure the data.

1. Read all the data in the relevant logical disk and save it to another disk.
2. Replace the drive module on a logical disk basis.
3. Rewrite all the data saved in Step (1).
4. Write the backup data equivalent to the lost data.

 **Note:** When multiple media errors are detected, a repair fault is generated. When the area whose repair was skipped is read at the end of the partial rebuild, a drive fault may be generated. You can see the generation of Repair Skip with the management software.

Temporary Degrade and Rebuild (Phoenix Feature)

When a media error occurs in a disk module, the disk module is internally degraded (temporary degrade), and the data is automatically overwritten or reassigned in the background and then regenerated. Then the disk module is reassigned to the original array structure upon completion of data regeneration. This feature allows the disk array unit to use the disk module having the media error without degrade, where in a conventional system this module would be degraded.

A

Controller DIP Switch Settings

- Controller DIP Switch Settings

Controller DIP Switch Settings

The controller modules contain DIP switches used for setting topology and data transfer rates. To access the DIP switches remove the controller from the DAU chassis, following removal procedures described in Chapter 3. Turn the controller over and set it on a clean surface in the position shown in Figure A-1.

The DIP switches on the controller are set as shown in Table A-1.

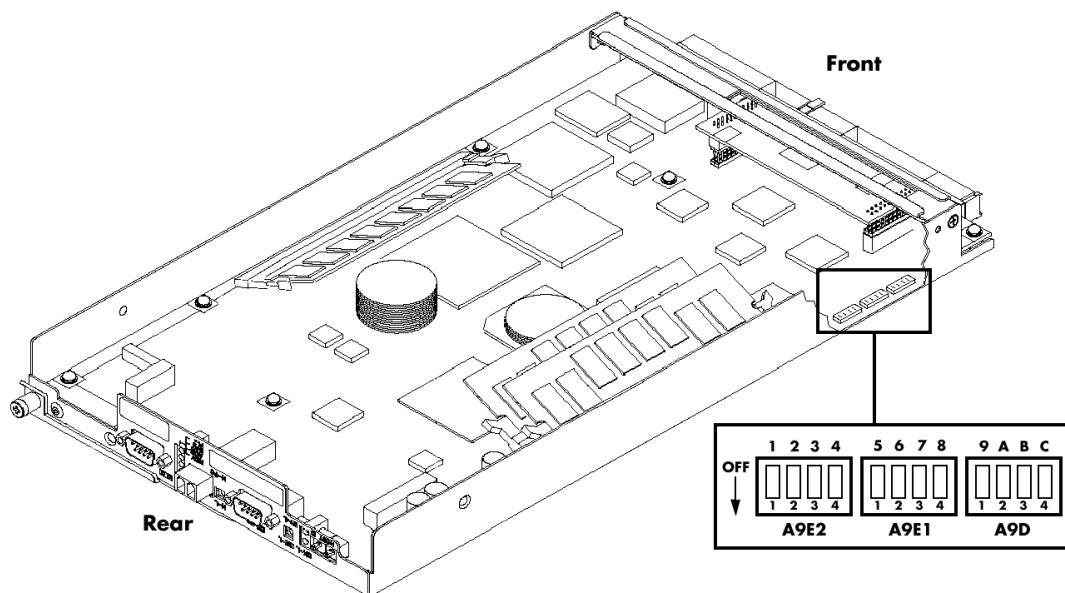

Figure A-1. Controller Dip Switches Location

Table A-1. DIP Switch Settings

Switch	Switch Position	Bit Position	Factory Setting	Description
A9E2	1	1	OFF	HDD Spin-up Mode OFF: Command ON: ON: Auto
	2	2	OFF	OEM Mode OFF: Normal ON: OEM product)
	3	3	OFF	Topology OFF: FC_AL ON: Fabric
	4	4	OFF	MD Mode OFF: Normal ON: Long MD
A9E1	1	5	OFF	Reserved
	2	6	OFF	Reserved
	3	7	OFF	Reserved
	4	8	OFF	Reserved
A9D	1	9	OFF	Reserved
	2	A	OFF	SES MODE OFF: SFF8067 ON: ESD
	3	B	ON	HOST MODE OFF: 1Gbps ON: 2Gbps
	4	C	ON	DE MODE OFF: 1Gbps ON: 2Gbps

Note: The DIP switch settings for CONT0 should be the same as that for CONT1.

The correlation between the AL-PA switch and AL-PA is shown in Table A-2.

Table A-2. AL-PA Switch Settings

AL_PA (hex)	Switch (hex)	AL_PA (hex)	Switch (hex)	AL_PA (hex)	Switch (hex)	AL_PA (hex)	Switch (hex)
EF	00						
E8	01						
E4	02	B1	21	72	40	3C	5F
E2	03	AE	22	71	41	3A	60
E1	04	AD	23	6E	42	39	61
E0	05	AC	24	6D	43	36	62
DC	06	AB	25	6C	44	35	63
DA	07	AA	26	6B	45	34	64
D9	08	A9	27	6A	46	33	65
D6	09	A7	28	69	47	32	66
D5	0A	A6	29	67	48	31	67
D4	0B	A5	2A	66	49	2E	68
D3	0C	A3	2B	65	4A	2D	69
D2	0D	9F	2C	63	4B	2C	6A
D1	0E	9E	2D	5C	4C	2B	6B
CE	0F	9D	2E	5A	4D	2A	6C
CD	10	9B	2F	59	4E	29	6D
CC	11	98	30	56	4F	27	6E
CB	12	97	31	55	50	26	6F
CA	13	90	32	54	51	25	70
C9	14	8F	33	53	52	23	71
C7	15	88	34	52	53	1F	72
C6	16	84	35	51	54	1E	73
C5	17	82	36	4E	55	1D	74
C3	18	81	37	4D	56	1B	75
BC	19	80	38	4C	57	18	76
BA	1A	7C	39	4B	58	17	77
B9	1B	7A	3A	4A	59	10	78
B6	1C	79	3B	49	5A	0F	79
B5	1D	76	3C	47	5B	08	7A
B4	1E	75	3D	46	5C	04	7B
B3	1F	74	3E	45	5D	02	7C
B2	20	73	3F	43	5E	01	7D



Specifications

- Disk Array Unit Basic Specifications
- Environmental Specifications
- Power Specifications
- Size and Weight Specifications
- Component Life Expectancies

Disk Array Unit Basic Specifications

Table B-1 shows the basic specifications of the disk array unit.

Table B-1. Disk Array Unit Specifications

Physical sector length (bytes/sector)	512
Number of standard disk drives per unit	3
Maximum number of disk drives per unit	15
Hot spare feature	Provided
Host interface specification (*1)	FC-AL / Fabric (Point to Point) [Optical]
Data transfer rate (*1)	200 MB/S, 100 MB/S
Disk drive interface specification	FC-AL [Copper]

Environmental Specifications

Table B-2 shows the environmental specifications of the disk array unit.

Table B-2. Environmental Specifications

	Operating	Non-Operating
Ambient temperature	5°C to 40°C	-10°C to 60°C
Relative humidity	10% to 80%	10% to 80%
Wet-bulb temperature (*1)	0°C to 27°C	-8°C to 29°C
Allowable vibration level	0.25 G	0.5 G

Power Specifications

Table B-3 shows the power specifications of the disk array unit.

Table B-3. Power Specifications

	Disk array unit
Input voltage	120 to 240 VAC \pm 10% (\times 2), 50/60 Hz
Maximum power consumption*	550 VA * Additional disk enclosure: 520 VA

**While the disk array unit can accept the power of 100 - 240 VAC (50/60 Hz), the power cord coming with the disk array unit can only accept 100 VAC. Use 100 VAC (50/60 Hz) when the attached power cord is used.*

Size and Weight Specifications

Table B-4 shows the external dimensions and weight of the disk array unit.

Table B-4. Size and Weight Specifications

	Disk array unit
Width	19.0 in (48.2 mm)
Height	5.16 in (13.1 mm) (3U)
Depth (including front mask)	23.4 in (59.4 mm)
Weight (in the maximum configuration)	Approx. 99.2 lbs (45.0 kg)

Component Life Expectancies

Table B-5 shows specific life expectancy specifications.

Table B-5 Component Life Expectancy Specifications

Battery	2.5 years
Fan (power supply)	50,000 hours

Equipment Log

Use this equipment log form to record pertinent information about your disk array unit. Be sure to update the equipment log when you add or remove components.

Record the model and serial numbers of the system components, dates of component removal or replacement, and the name of the vendor from whom the component was purchased.

Record the model and serial numbers of the disk array unit. The model and serial numbers of the system unit are recorded on a label attached to the rear of the unit.

The location of serial numbers on hard disk drives varies from one manufacturer to another. Literature accompanying these products should illustrate or describe the location of model and serial numbers.

Component	Manufacturer Name & Model	Serial Number (if available)	Date Installed
Disk Array Unit			
Controller 0 (CONT0)			
Controller 1 (CONT1)			
SVP Service Processor			
Power Supply 0			
Power Supply 1			
Battery Backup Unit 0			
Battery Backup Unit 0			
Cache Memory			
Hard Disk Drive 1			
Hard Disk Drive 2			
Hard Disk Drive 3			
Hard Disk Drive 4			
Hard Disk Drive 5			
Hard Disk Drive 6			
Hard Disk Drive 7			
Hard Disk Drive 8			
Hard Disk Drive 9			
Hard Disk Drive 10			
Hard Disk Drive 11			
Hard Disk Drive 12			
Hard Disk Drive 13			
Hard Disk Drive 14			
Hard Disk Drive 15			

2 Equipment Log

Glossary

A

Arbitrated Loop Technology

A Fibre Channel topology that provides an (FC-AL) solution to communicating ports in a loop.

Arbitration

The process of selecting one respondent from a collection of several candidates that request service concurrently.

Asynchronous Operations

Operations that bear no relationship to each other in time but can overlap. The concept of asynchronous I/O operations is central to independent access arrays in throughput-intensive applications.

B

Broadcast

Sending a transmission to all N_Ports on a fabric.

C

Cache Flush

Refers to an operation where all un-written blocks in a Write-Back Cache are written to the target disk. This operation is necessary before powering down the system.

Channel

A point-to-point link, the main task being transporting data from one point to another.

Cluster

A group of independent computer systems working together as a single system, using a shared disk storage such as a disk expansion unit (DEU). In a two-node cluster, both servers are "active," i.e. servicing client requests just like two network servers. If one of the servers fails, the surviving server initiates a "failover" and the applications running on the failed server can be moved to the surviving server, transparently to clients.

Consistency Check

Refers to a process where the integrity of redundant data is verified. For example, a consistency check of a mirrored drive will make sure that the data on both drives of the mirrored pair are exactly the same. For RAID level 3 and 5 redundancy, a consistency check will involve reading all associated data blocks, computing parity, reading parity, and verifying that the computed parity matches the read parity.

Controller

A computer module that interprets signals between a host and a peripheral device.

CRC (cyclic redundancy check)

An error correcting code used in Fibre Channel

D**Disconnect/Reconnect**

Disconnect is a function that allows a target SCSI device (typically a disk drive that received a request to perform a relatively long I/O operation) to release the SCSI bus so that the controller can send commands to other devices. When the operation is complete and the SCSI bus is needed by the disconnected target again, it is reconnected.

Disk Mirroring

Data written to one disk drive is simultaneously written to another disk drive. If one disk fails, the other disk can be used to run the system and reconstruct the failed disk.

Disk Spanning

Several disks appear as one large disk using this technology. This virtual disk can then store data across disks with ease without the user being concerned about which disk contains what data. The subsystem handles this for the user.

Disk Striping

Data is written across disks rather than on the same drive. Segment 1 is written to drive 0, segment 2 is written to drive 1, and so forth until a segment has been written to the last drive in the chain. The next logical segment is then written to drive 0, then to drive 1, and so forth until the write operation is complete.

Duplexing

This refers to the use of two controllers to drive a disk subsystem. Should one of the controllers fail, the other is still available to provide disk I/O. In addition, depending how the controller software is written, both controllers may work together to read and write data simultaneously to different drives.

F**Fabric**

A group of interconnections between ports that include a fabric element.

Fault-Tolerant

When something is fault-tolerant it is resistant to failure. A RAID 1 mirrored subsystem, for example, is fault-tolerant because it can still provide disk I/O if one of the disk drives in a mirrored system fails.

F_Port

A port in the fabric where an N_port or NL_port may attach.

FCP

Fibre Channel Protocol.

FL_Port

A port in fabric where an Nport or an NL_Port may attach.

Fibre Channel

Up to 2 Gigabit per second data transfer interface technology that maps several common transport protocols including IP and SCSI, allowing it to merge high-speed I/O and network functionality in a single connectivity technology.

Full duplex

A communication protocol that permits simultaneous transmissions in both directions, usually with flow control.

H**Hot Spare**

The “Hot Spare” is one of the most important features the controller provides to achieve automatic, non-stop service with a high degree of fault tolerance. This rebuild operation will be carried out by the controller automatically when a SCSI disk drive fails.

L**Logical Drive**

A set of contiguous chunks of a physical disk. Logical disks are used in array implementations as constituents of logical volumes or partitions. Logical disks are normally transparent to the host environment, except when the array containing them is being configured.

M**Mapping**

The conversion between multiple data addressing schemes, especially conversions between member disk block addresses of the virtual disks presented to the operating environment by the array management software.

Mirroring

Refers to the 100% duplication of data on one disk drive to another disk drive. Each disk will be the mirror image of the other.

P**Partition**

An array virtual disk made up of logical disks rather than physical ones. Also called logical volume.

Physical Drive

A physical array (or drive) is a collection of physical disks governed by the RAID management software. A physical drive appears to the host computer as one or more logical drives.

R**RAID**

(Redundant Array of Independent Disks) An approach to using multiple low cost drives as a group to improve performance, yet also provide a degree of redundancy that makes data loss remote.

RAID 0

Block “striping” is provided, yielding higher performance than is possible with individual drives. This level does not provide any redundancy.

RAID 1

Drives are paired and mirrored. All data is 100% duplicated on an equivalent drive.

RAID 10

RAID 10 is a combination of RAID levels 0 and 1. The data is striped across disks as in RAID 0. Each disk has a mirror disk, as in RAID 1.

RAID 3

Data is striped across several physical drives. For data redundancy one drive is encoded with rotated XOR redundancy.

RAID 30

Data striping of two or more RAID 3 arrays. RAID level 30 is a combination of 0 and 3.

RAID 5

Data is striped across several physical drives. For data redundancy drives are encoded with rotated XOR redundancy.

RAID 50

RAID level 50 is a combination of RAID level 0 and 5.

RAID Controller

This refers to the controller card that routes data to and/ or from the CPU. Disk array controllers perform all RAID algorithms onboard the controller.

Rebuild

The regeneration of all data from a failed disk in a RAID level 1, 3, 5, or 6 array to a replacement disk. A disk rebuild normally occurs without interruption of application access to data stored on the array virtual disk.

Rotated XOR Redundancy

This term (also known as “parity”) refers to a method of providing complete data redundancy while requiring only a fraction of the storage capacity for redundancy. In a system configured under RAID 3 and 5, all data and parity blocks are divided between the drives in such a way that if any single drive is removed (or fails), the data on it can be reconstructed using the data on the remaining drives. (XOR refers to the Boolean “Exclusive-OR” operator.)

S**SAF-TE**

Is the acronym for SCSI Accessed Fault-Tolerant Enclosures. It is a monitoring and communication specification developed by Conner (*nStor*) and Intel for sending and receiving server and storage system status information via the SCSI bus.

Session

Refers to the period of time between any two consecutive system shutdowns. System shutdown may be either a power off/on, or a hardware reset.

SCSI Drive

A disk drive equipped with a small computer system interface (SCSI). Each disk drive will be assigned a SCSI address (or SCSI ID), which is a number from 0 to 15. The SCSI address uniquely identifies the drive on the SCSI bus or channel.

Spanning

Disk spanning allows multiple disk drives to function like one big drive. Spanning overcomes lack of disk space and simplifies storage management by combining existing resources or adding relatively inexpensive resources.

Striping

Disk striping writes data across multiple disks rather than on one disk. disk striping involves partitioning each drive storage space into stripes that can vary in size from one sector (1 KB) to several megabytes.

Stripe Order

The order in which SCSI Drives appear within a Physical Pack. This order must be maintained, and is critical to the controller’s ability to “Rebuild” failed drives.

Stripe Width

Refers to the number of kilobytes per stripe block.

T

Target ID

A target ID is the SCSI ID of a device attached to the disk array controller. Each SCSI channel can have up to sixteen SCSI devices (target ID from 0 to 15) attached to it.

W

Write-Through Cache

Refers to a cache writing strategy whereby data is written to the SCSI Drive before a completion status is returned to the host operating system. This caching strategy is considered more “secure,” since a power failure will be less likely to cause loss of data. However, a Write-Through cache results in a slightly lower performance, in most environments.

Index

A

Accessing the DAU, 3-3

C

Cable Dressing, 2-16

Care and Handling, x

Cleaning, 4-2

Connecting the Power Cord(s), 2-13

D

DAU Controls and Indicators, 1-15

DAU Security, 1-4

DAU Startup, 4-3

F

Fans, 1-4

Features and Indicators, 1-15

Front Chassis Features and Indicators, 1-15

H

Hard Disk Drives

 Installing or Swapping, 3-4

Hot Swappable Power Supplies, 1-4

Hot Swappable SCSI Disk Drive Bays, 1-4

L

Line voltage, 2-13

M

Maintenance and Troubleshooting, 4-1

O

Overview, 1-2

P

Power

 Connecting, 2-13

Power Supplies, 1-4

R

Rack-Mount Subsystem Assembly, 2-5

Rear Chassis Features and Indicators, 1-17

Redundant Cooling Fans, 1-4

Routine Maintenance, 4-2

S

Safety Notices, ix

SCSI Disk Drive Bays, 1-4

Security, 1-4

Selecting a Site, 2-2

Setting Up Your DAU, 2-1

T

Text Conventions, viii

Troubleshooting, 4-4

Troubleshooting Tables, 4-4

U

Unpacking the DAU and Rack Mounting
 Hardware, 2-3

Upgrading Your DAU, 3-1

Using this Guide, vii

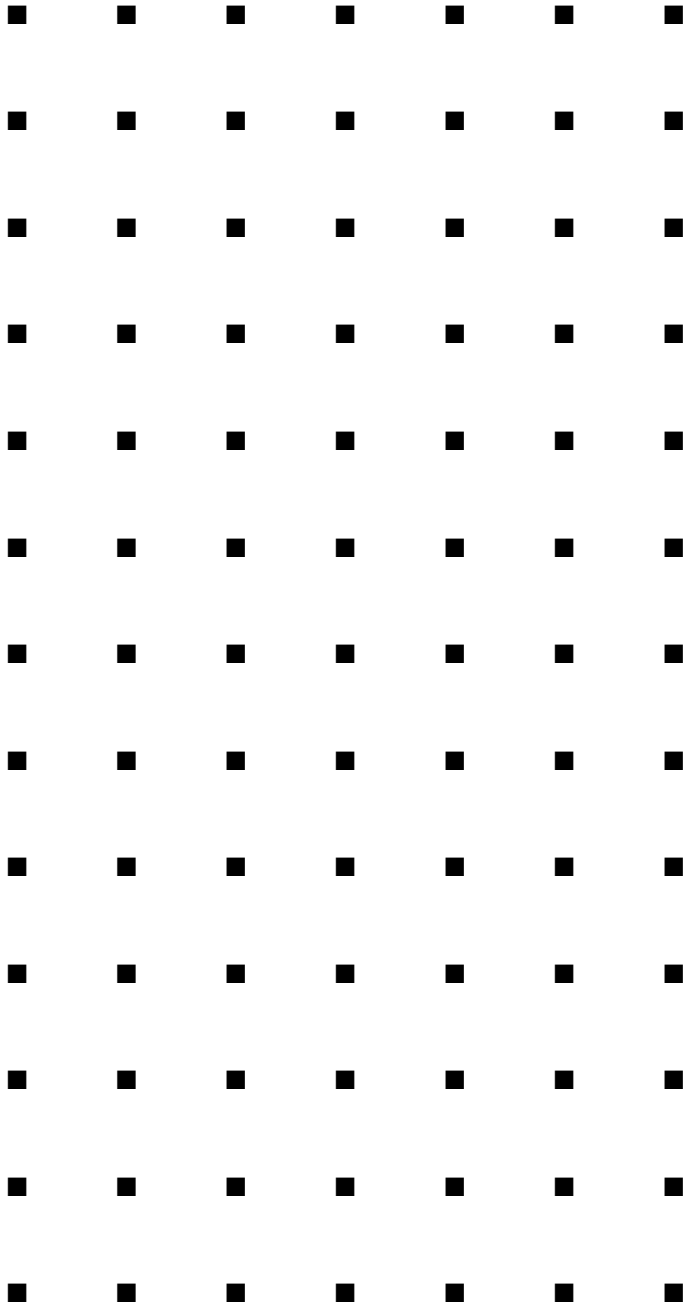

456-01689-000